

MAINTENANCE GUIDE FOR THE JVK-60 SERIES FLOW METER

(Shown w/ IR-P Sinking Sensor)

* Cleaning, inspecting and/or replacing parts can be done by following the procedure below.*

Read the entire procedure before taking apart the meter. Be careful when handling parts!

- 1) Remove the sensor (1) from the meter by loosening the 3 set screws (2c) with a 3mm hex key.
- 2) Remove the Sensor Adapter (2a), by removing the M4 Screws (2b).
- 3) Loosen the Socket Cap Screws (3) from the nuts (12) by using a 5mm hex key for the bolts and a 10mm socket for the nuts. Also, remove the spring washers (4) and flat washers (5).
- 4) Separate the upper and lower housings (6) & (11). Insert 2 hex keys or similar tools into the 2 holes (*). Using a small hammer and holding the upper housing, lightly tap the hex keys to separate the housings. Alternate tapping the hex keys to avoid damage to the locating pin holes. **Do not use a screwdriver or other tools to pry apart the housings as this can cause permanent damage to the flow meter bodies and internal parts.**
- 5) Once the housings are separated:
 - a. Remove the gears (8). Inspect the gears and clean if needed. **Be careful not to drop the gears as this will damage them.**
 - b. Remove the shafts (7), inspect them and clean them if needed.
 - c. Clean out the cavity in the upper and lower housings and inspect them for damage and/or wear.
 - d. Replacing the teflon o-ring (9) is recommended to ensure sealing once reassembled.
- 6) To reassemble the meter:
 - a. Insert the o-ring (9) into the o-ring groove.
 - b. Insert the shafts (7) back into the shaft holes.
 - c. Insert the gears back into place. Make sure they are able to freely spin.
 - d. Rejoin the upper and lower housings together, using the locating pins (10) to guide the positioning of the housings.
 - e. Reinsert the bolts, washers and nuts. **Torque down 6 bolts specified to 3.5 ft/lbs and 4 bolts specified to hand tight (just snug). (See diagram on next page for recommended order to tighten bolts)**
 - f. Reinstall the sensor adapter (2) and sensor (1). **Do Not Over Tighten** the screws (3) as you can strip the threads in the meter body.

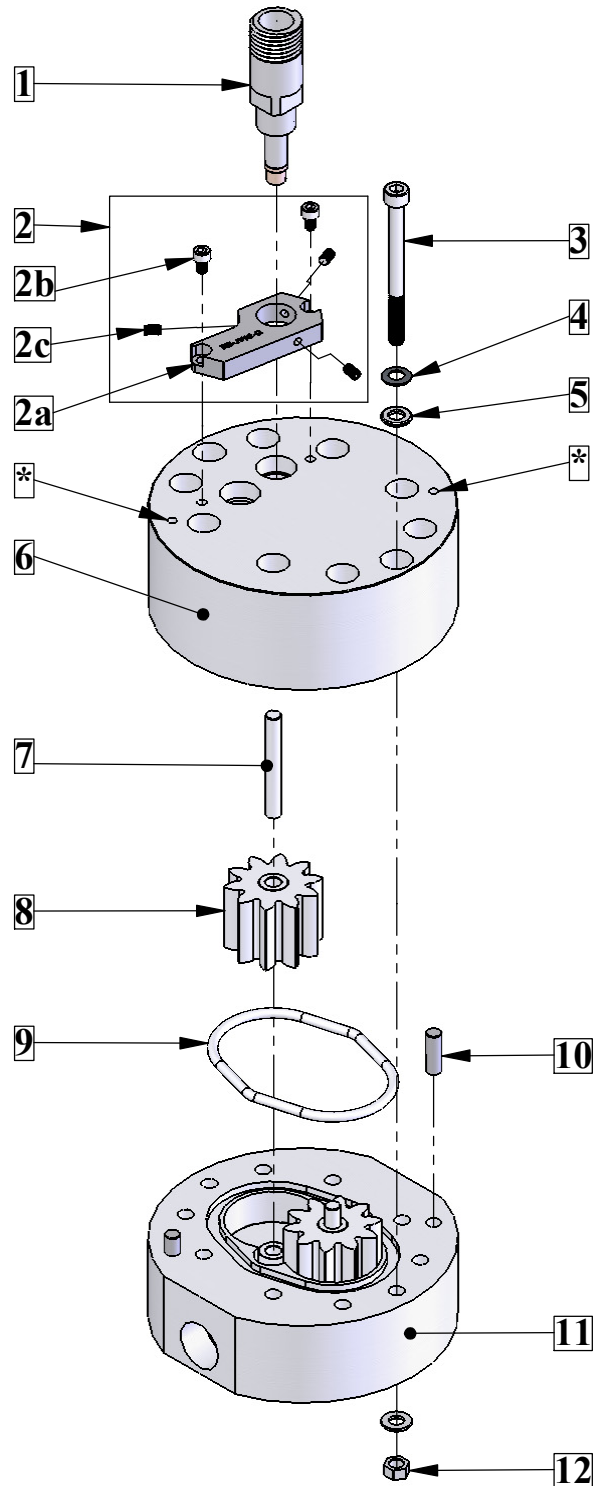

CROSS REFERENCE GUIDE FOR JVK-60 SERIES SPARE PARTS

Part - Qty. per meter [Drawing Ref. #]	AW Part Number Part Description
Sensor - 1 [1]	AP60010 IR-P Optical Sinking Sensor
Sensor Adapter - 1 [2]	BZ15220 JVx-xG Sensor Adapter
M4x0.7 x 8mm Screw - 2 [2b]	Included w/ Sensor Adapter Not sold individually
8-32 x 1/4" Set Screw - 3 [2c]	Included w/ Sensor Adapter Not sold individually
Bolts - 10 [3]	BZ05325 M6 x 1.0 x 70mm
Spring Washers - 10 [4]	SR90350 Stainless Steel Belleville Spring Washer
Washers - 20 [5]	SR90290 Stainless Steel M6 Flat Washer
Upper Housing - 1 [6]	BH70010 JUK-60 Kynar Upper Housing
Shafts - 2 [7]	BS21075 JST-60 Ceramic Shaft
Teflon Gears - 2 [8]	BG23077 JGR-60 Teflon Gear
Teflon O-Ring - 1 [9]	BO20040 COT-04 Teflon O-Ring
Locating Pins - 2 [10]	BZ25260 JV-60KL Locating Pin
Lower Housing - 1 [11]	BH70015 JLK-60 Kynar Lower Housing
Nuts - 10 [12]	SR90295 Stainless Steel M6 Nut

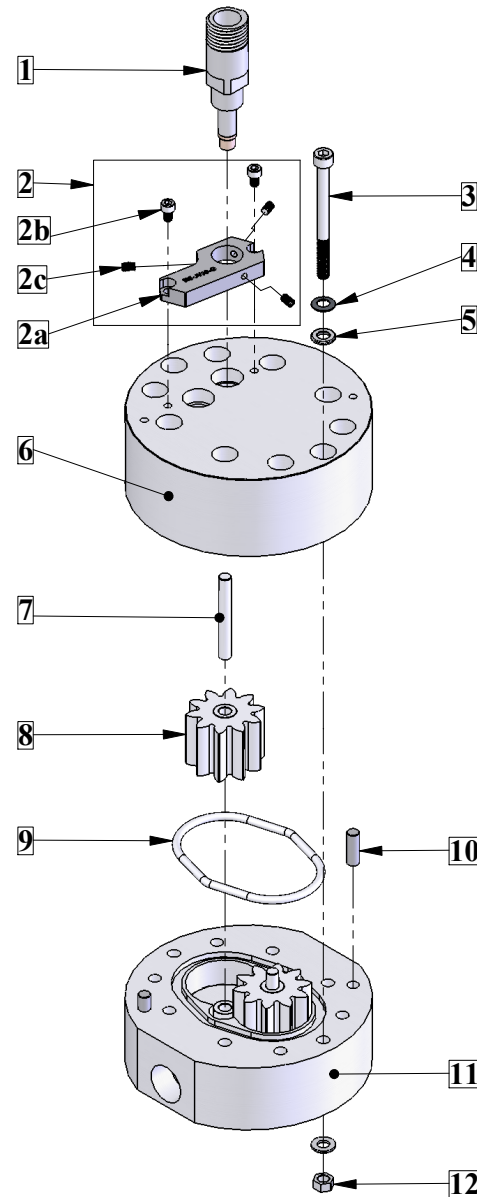

Recommended Bolt Torque Pattern #s 1-6

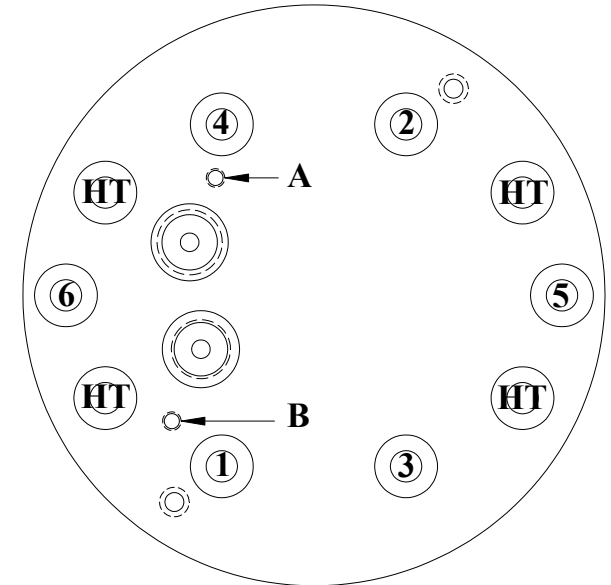

**Holes Labeled "HT" = Hand Tight
Holes labeled "A" & "B" are sensor bracket
mounting holes.**