

DESILTER

Operating And Service Manual

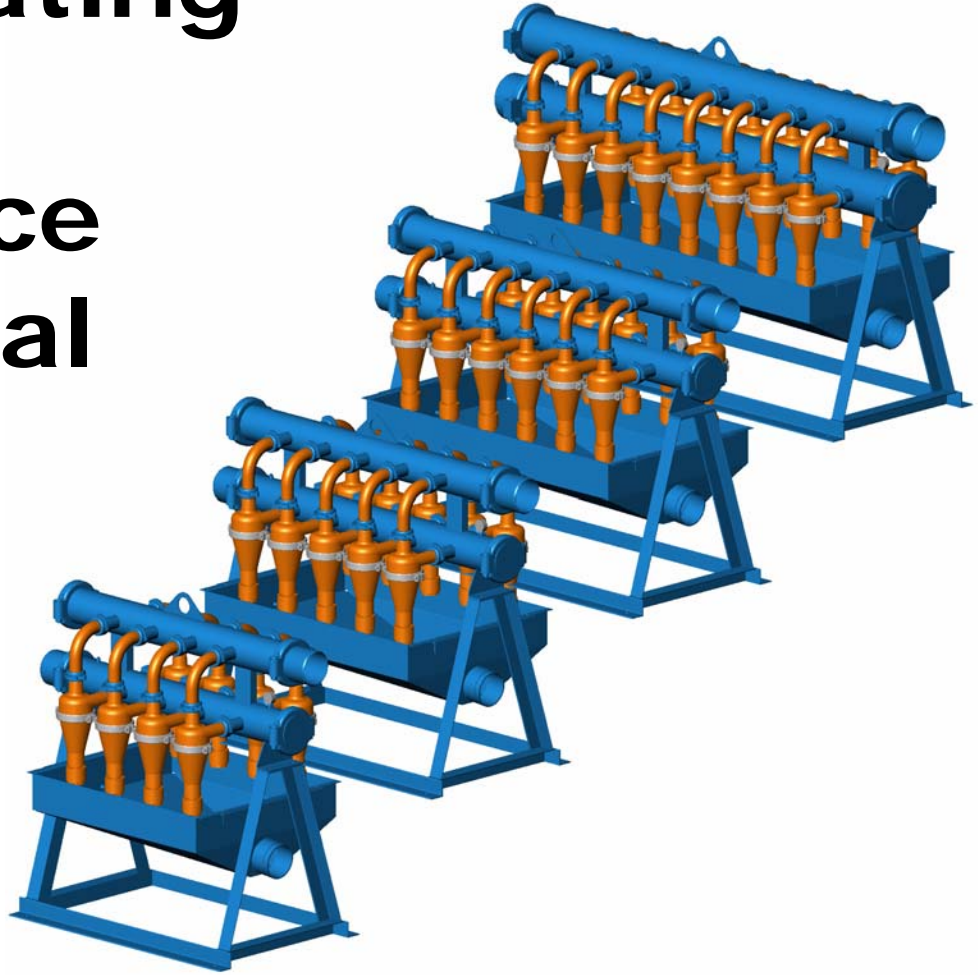

PROCESS SOLUTIONS INTERNATIONAL

Manufacturing and Sales

5119 Hiltonview Drive

Houston, TX 77086

281-893-4774 phone

866-866-4774 (4PSI)

281-893-1027 fax

www.psimax2000.com

All rights reserved. This publication is the property of, and contains information proprietary to PROCESS SOLUTIONS INTERNATIONAL. No part of this publication may be reproduced in any form or by any means, including electronic, mechanical, or otherwise, without the prior written permission of PROCESS SOLUTIONS INTERNATIONAL. Information contained within this publication is subject to change without notice.

© Copyright 2006 PROCESS SOLUTIONS INTERNATIONAL

Publication date: October 2006

DISCLAIMER

Recommendations made by PROCESS SOLUTIONS INTERNATIONAL are advisory only. PROCESS SOLUTIONS INTERNATIONAL shall not be liable under any guarantees or warranties, expressed or implied, in any manner or form, for the failure to obtain any particular results from the use of any recommendation made by it or from the use of this material, or for incidental or consequential damages.

CONTENTS

PART 1	INTRODUCTION	5
PART 2	DESCRIPTION.....	6
PART 3	INSTALLATION.....	7
3.1	LOCATION	7
<i>FIG. 1</i>	<i>EXAMPLE OF A THREE PIT SYSTEM</i>	<i>8</i>
3.2	SUCTION PIPING.....	9
3.3	FEED PIPING	10
3.4	OVERFLOW PIPING.....	10
3.5	SOLIDS DISCHARGE LINE	11
PART 4	OPERATION	12
4.1	STARTING AND STOPPING PROCEDURES.....	12
<i>FIG. 2</i>	<i>HEAD REQUIRED AT THE FEED MANIFOLD</i>	<i>12</i>
4.2	PERFORMANCE	13
<i>FIG. 3</i>	<i>DESILTER NOMOGRAPH</i>	<i>14</i>
PART 5	MAINTENANCE.....	15
5.1	ADJUSTMENT.....	15
<i>FIG. 4</i>	<i>APEX.....</i>	<i>15</i>
PART 6	SPECIFICATIONS	16
6.1	SPECIFICATION DRAWINGS	17
<i>FIG. 1</i>	<i>DESILTER FRONT VIEW</i>	<i>17</i>
<i>FIG. 2</i>	<i>DESILTER TOP VIEW</i>	<i>18</i>
<i>FIG. 3</i>	<i>DESILTER END VIEWS.....</i>	<i>19</i>
<i>FIG. 4</i>	<i>DESILTER MOUNTING DETAILS</i>	<i>20</i>
<i>FIG. 5</i>	<i>NOZZLE SCHEDULE</i>	<i>21</i>

PART 7	DRAWINGS AND PARTS LISTS	22
7.1	8-4 DESILTER	22
<i>FIG. 6</i>	<i>8-4 PARTS LIST</i>	22
<i>FIG. 7</i>	<i>8-4 ASSEMBLY.....</i>	23
7.2	10-4 DESILTER.....	24
<i>FIG. 8</i>	<i>10-4 PARTS LIST.....</i>	24
<i>FIG. 9</i>	<i>10-4 ASSEMBLY.....</i>	25
7.3	12-4 DESILTER.....	26
<i>FIG. 10</i>	<i>12-4 PARTS LIST.....</i>	26
<i>FIG. 11</i>	<i>12-4 ASSEMBLY.....</i>	27
7.4	16-4 DESILTER.....	28
<i>FIG. 12</i>	<i>16-4 PARTS LIST.....</i>	28
<i>FIG. 13</i>	<i>16-4 ASSEMBLY.....</i>	29
PART 8	SPARE PARTS LISTS	30
<i>FIG. 14</i>	<i>8-4 SPARE PARTS.....</i>	30
<i>FIG. 15</i>	<i>10-4 SPARE PARTS.....</i>	31
<i>FIG. 16</i>	<i>12-4 SPARE PARTS.....</i>	32
<i>FIG. 17</i>	<i>16-4 SPARE PARTS.....</i>	33
PART 9	TROUBLESHOOTING	34
APPENDIX A	IMPELLER SIZES.....	38
<i>FIG. 18</i>	<i>IMPELLER SIZES FOR 5X6 PUMPS AT 1600 RPM.....</i>	39
<i>FIG. 19</i>	<i>IMPELLER SIZES FOR 5X6 PUMPS AT 1750 RPM.....</i>	40
<i>FIG. 20</i>	<i>IMPELLER SIZES FOR 6X8 PUMPS AT 1600 RPM.....</i>	41
<i>FIG. 21</i>	<i>IMPELLER SIZES FOR 6X8 PUMPS AT 1750 RPM.....</i>	42

PART 1 INTRODUCTION

The PROCESS SOLUTIONS INTERNATIONAL Desilter is used to remove "silt" size particles from drilling fluids. "Silt" refers to all particles smaller than sand sizes (74 microns) and larger than colloidal material (about 2 microns). The word "silt" applies here only to size. The "silt" solids may actually be shale, limestone, silica sand, barite or any other material of silt size which may be present.

Normally a Desander first removes the solid particles that are 74 microns or larger "sand". Then the Desilter removes the "silt". If a Desander is not operating ahead of the Desilter, the Desilter will perform first as a Desander until the sand particles are removed first and then it will start to remove the silt.



8-4 DESILTER



10-4 DESILTER

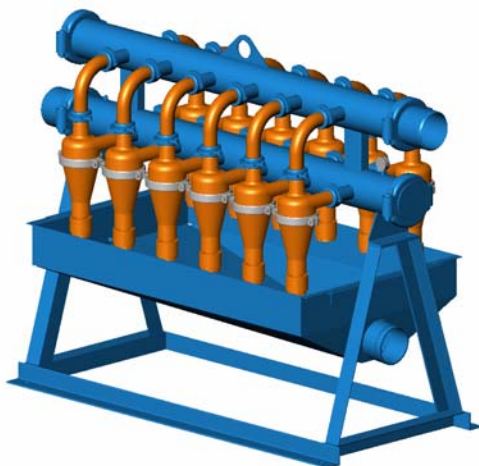

12-4 DESILTER

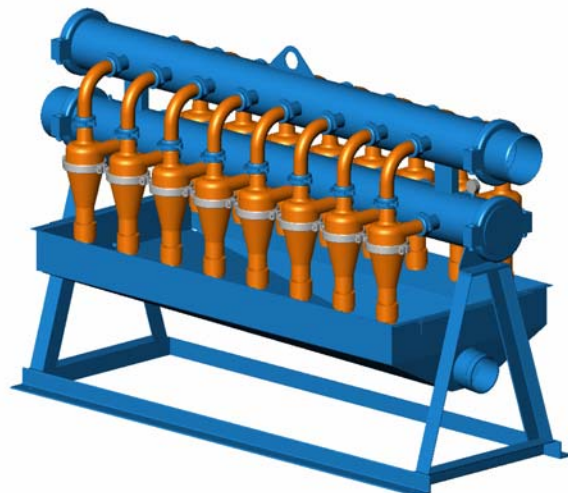

16-4 DESILTER

PART 2 DESCRIPTION

PROCESS SOLUTIONS INTERNATIONAL Desilters are hydrocyclone solids separators. As their name implies, they remove "silt" size particles from the drilling fluid.

To be effective the Desilter should be sized to process 150% of the circulation rate and the mud to be desiltered should be fed from the desander mud compartment.

PROCESS SOLUTIONS INTERNATIONAL Desilters consist of an assembly of hydrocyclone solids separators. The assembly includes mounting of eight to sixteen cones on heavy duty steel supports together with a feed manifold, overflow manifold, and a steel collecting trough.

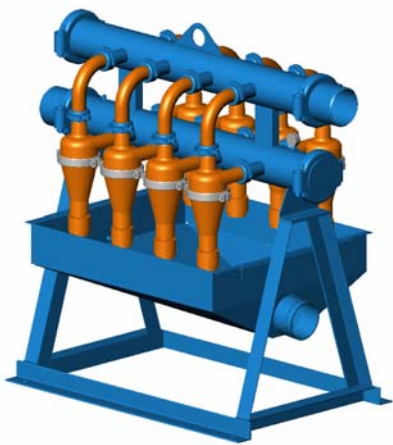

8-4 DESILTER



10-4 DESILTER



12-4 DESILTER

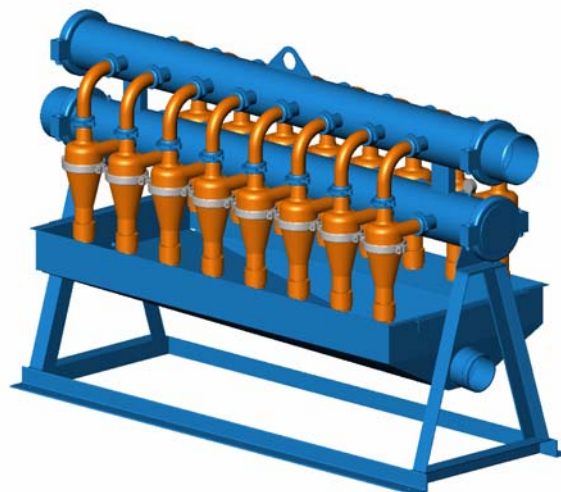

16-4 DESILTER

PART 3 INSTALLATION

3.1 LOCATION

The Desilter should be located to meet the following conditions:

1. The Desilter feed suction should be where it picks up mud that has been through a Degasser and a Desander, if these are present.
2. Since the Desilter should handle more mud than is being circulated through the hole, an equalizer line or over flow zone must be provided to return the extra mud to the Desilters feed (suction) point.
3. An equalizer near the bottom of the pit is preferable to a top equalizer for returning the back flow.
4. The flow between tanks should be controlled so that the mud cannot reach the next tank except through the Desilter. A bypass such as an equalizer line should be provided for those times when the Desilter is not being operated.
5. The overflow desilted mud should enter the next tank section after the Desilter feed suction point.
6. The underflow discharge should be located so that a gravity flow can carry the separated solids to some collection point such as a waste pit. A small stream of water can be used to help the flow of the solids.

Below is one possible example to meet these requirements on a three pit system.

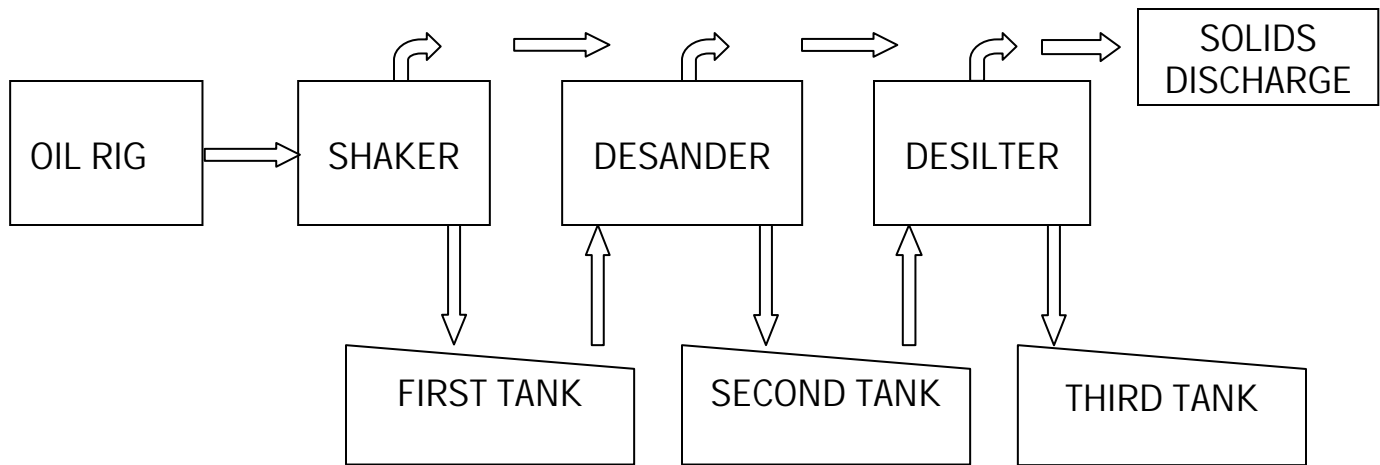

FIG. 1 EXAMPLE OF A THREE PIT SYSTEM

3.2 SUCTION PIPING

The suction piping to the pump should be at least as large as the inlet of the pump. If the suction line is longer than about 10 feet it should be about two inches larger than the pump inlet to prevent loss of pressure head. The piping should attach to the tank at a tank flange. A full opening valve which provides a full shut-off should be used in the line so the pump can be serviced without having to empty the tank.

The intake of the suction lines, inside the tank, should have an elbow facing down about 12 to 18 inches above the bottom of the tank to reduce the chance of picking up large rocks and trash which could tend to plug the suction line or damage the pump. If the suction line is higher than 18 inches it will cause a vortex and will take air into it even when the tank is reasonably full.

If a suction hose is used and is dropped into the tank it must have a heavy duty screen with 5/8 inch or 3/4 inch openings to screen out large particles that could plug the cone or damage the pump. The screen should be easily removable for inspection and cleaning.

If possible the pump should be below the operating mud level to provide self-priming and to reduce pressure loss. If the pump is higher than the mud level it is most important to use a foot valve in the suction line.

Use as few elbows as possible. The elbows should be large radius elbows to reduce the friction loss and to help maintain the effective pump pressure at the feed manifold.

3.3 FEED PIPING

The feed piping from the pump to the feed manifold must be at least 6 inches in diameter and must have as few elbows as possible. For the 16-4 Desilter the feed line should be at least 8 inches in diameter. The elbows should be large radius elbows to minimize losses.

3.4 OVERFLOW PIPING

The overflow piping from the overflow manifold carries the desilted mud back to the pits. This line must discharge above the mud level to prevent a siphon effect. It should be horizontal or sloping slightly downward toward the discharge end. The elbows should be large radius elbows.

If it is necessary for the mud to drop a long distance to the mud level the discharge line must empty into a separate container which is open to the air and which has its own piping down to the mud level. This avoids a siphon effect on the cones. The siphon effect will stop the discharge of the silt at the apex. An alternate method is to weld a 1 inch vacuum breaking line equipped with a valve into the overflow manifold. This lets air into it when needed instead of pulling air through the apex valve.

The discharge line should not slope upward from the overflow manifold. Raise the Desilter so that no lift is required in the discharge piping. The back-pressure from a rising discharge line forces additional mud out the apex valve and increases the loss of whole mud to the underflow.

3.5 SOLIDS DISCHARGE LINE

The two main factors in moving the separated solids to a waste area are:

1. Sufficient slope in the solids discharge piping or trough.
2. A water flush to help the solids flow when there is a large amount of solids large enough to settle out of the underflow mud.

A minimum slope of about one foot for every three feet of discharge trough is recommended when a water flush is being used. If the recommended slope cannot be provided a water jet line into the sand discharge pipe will help carry the solids down it.

The discharged solids must not be allowed to back up and cover the apex of the cones. If it should cover the apex it would force more silt to be carried back to the mud system in the overflow.

PART 4 OPERATION

4.1 STARTING AND STOPPING PROCEDURES

Open the suction valve if there is one.

Start the pump and bring it up to full normal speed or until the feed pressure is enough to give about 90 feet of head at the existing mud weight. If the pressure cannot be brought within 10% of the required pressure, the performance of the Desilter will be poor and the underflow loss may be excessive. See FIG. 2 page 12.

When the Desilter is stopped close the suction line valve if the pump is below the mud level.

**HEAD REQUIRED (FEET) AT THE FEED MANIFOLD
FOR VARIOUS PRESSURES AND MUD WEIGHTS**

	8.5 LB/GAL	9.0 LB/GAL	9.5 LB/GAL	10.0 LB/GAL	10.5 LB/GAL
30 PSI	68	64	61	58	55
35 PSI	79	75	71	67	64
40 PSI	91	86	81	77	73
45 PSI	102	96	91	86	82
50 PSI	113	107	101	96	92

FIG. 2 HEAD REQUIRED AT THE FEED MANIFOLD

4.2 PERFORMANCE

Two convenient measures of Desilter performance are the weight of the underflow and the weight of the overflow. With a spray discharge from the apex of the cone the underflow weight should be between 2.5 and 3.5 lb/gal (0.30 and 0.42 kg/liter) heavier than the feed mud. The overflow weight should be slightly lower than the feed weight, but this difference may be less than 0.1 ppg.

The amount of silt being removed by the Desilter can be calculated approximately by the *Nomograph For Estimating Hydrocyclone Performance* table. See FIG. 3 page 14. To do this the underflow weight and volume rate (both as to volume and the time for that volume) must be accurately measured.

It is very important to maintain a spray discharge to have efficient desilting. A rope discharge means that the mud and solids have lost their circular motion before reaching the opening and the cyclone action has stopped somewhere up in the cone. When the rotation stops there is no more separation and the internal pressure pushes part of the remaining mud out of the apex along with whatever solids were separated before the rotation was lost. This loss of rotation may be due to high mud viscosity, but most often is due to having too small a hole to let all the solids out at the rate they are being separated. This fills the apex end of the cone with concentrated slurry of solids that has too much viscosity to continue the rotation.

In this case the weight of the underflow will be high and the discharge will feel somewhat gritty (because it is mostly large particles), But the rate of underflow will be less than for a spray discharge and the total silt removed will be seriously reduced.

Nomograph For Estimating Hydroclone Performance

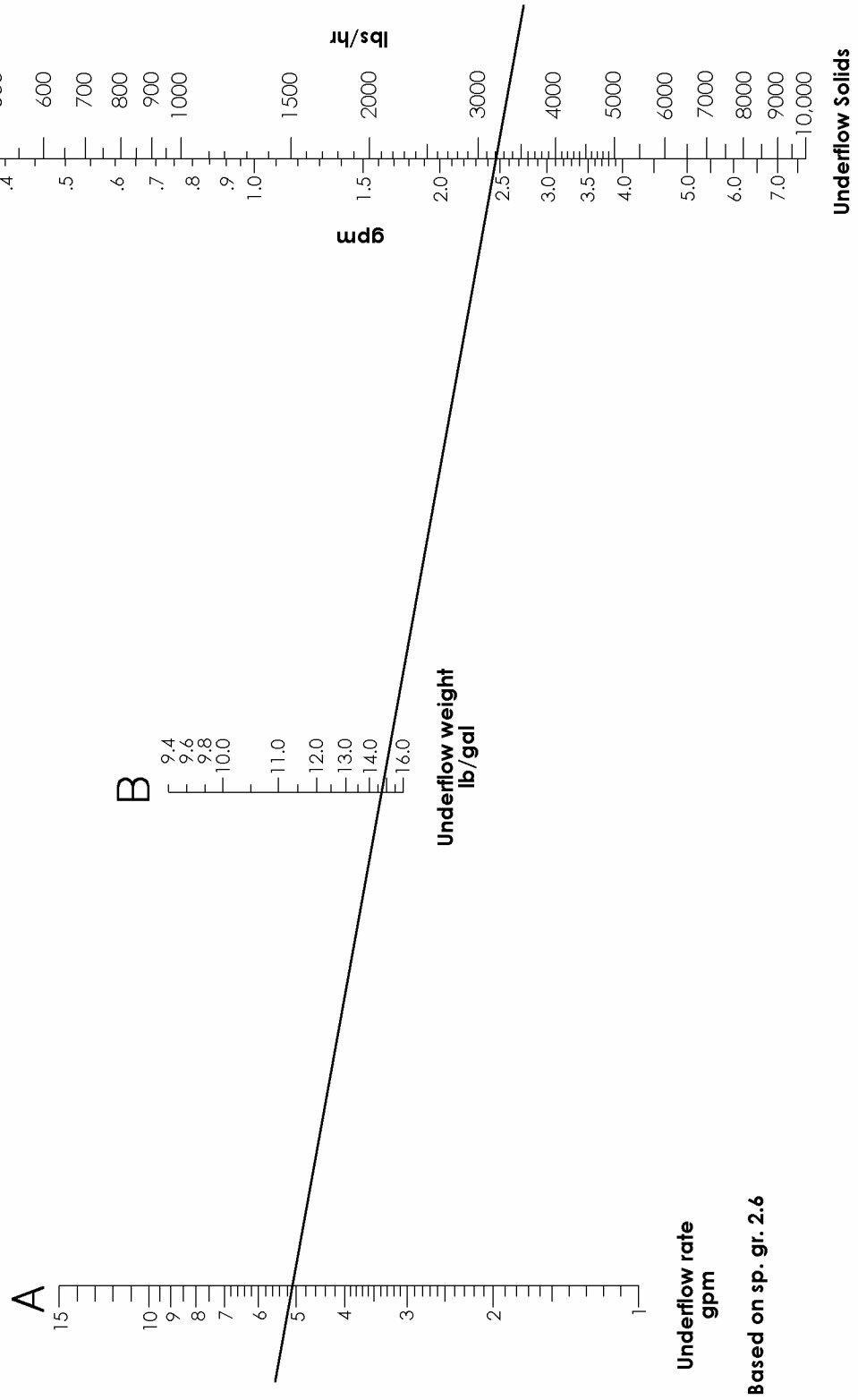

FIG. 3 DESILTER NOMOGRAPH

PART 5 MAINTENANCE

5.1 ADJUSTMENT

The only adjustment to be made on the Desilter is the apex size. See FIG. 4 PAGE 15. The correct size depends primarily on the amount of silt present in the mud. When possible the apex should be just large enough to make the silt and mud discharge in a definite spray pattern most of the time. If the apex is too large the underflow may lose a little extra mud without much benefit.

If the apex is too small for the solids content of the mud, the discharge will be a "rope" instead of a spray, and some of the silt that should be removed will be forced back into the overflow and kept in the system. This causes a serious loss of desilting efficiency.

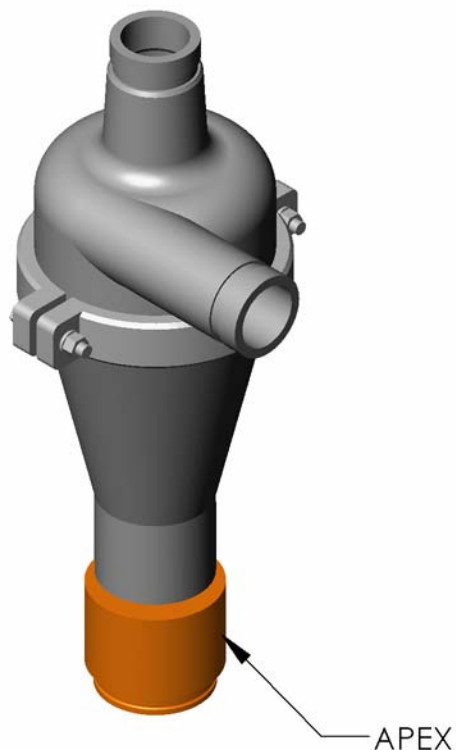

FIG. 4 APEX

PART 6 SPECIFICATIONS

1. Overall Length:

- a. 8-4 Desilter – 68.00inches [1727.2 mm]
- b. 10-4 Desilter - 78.00inches [1981.2 mm]
- c. 12-4 Desilter - 88.00inches [2235.2 mm]
- d. 16-4 Desilter - 108.00inches [2743.2 mm]

2. Overall Height: 64.00 inches [1625.6 mm]

3. Overall Width: 36.00 inches [914.4 mm]

4. Weight:

- a. 8-4 Desilter – 750 lbs. [340 Kg]
- b. 10-4 Desilter - 900 lbs. [408 Kg]
- c. 12-4 Desilter - 1050 lbs. [476 Kg]
- d. 16-4 Desilter - 1500 lbs. [680 Kg]

6.1 SPECIFICATION DRAWINGS

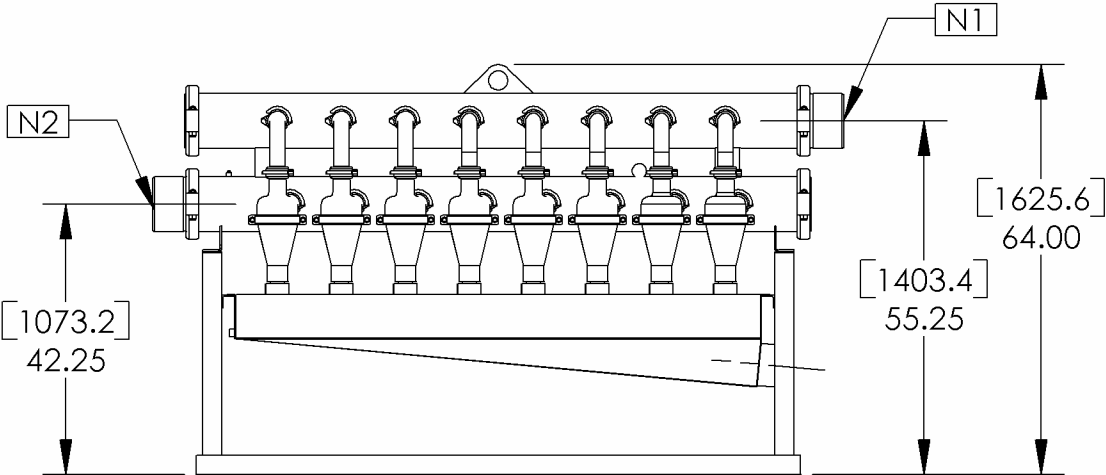
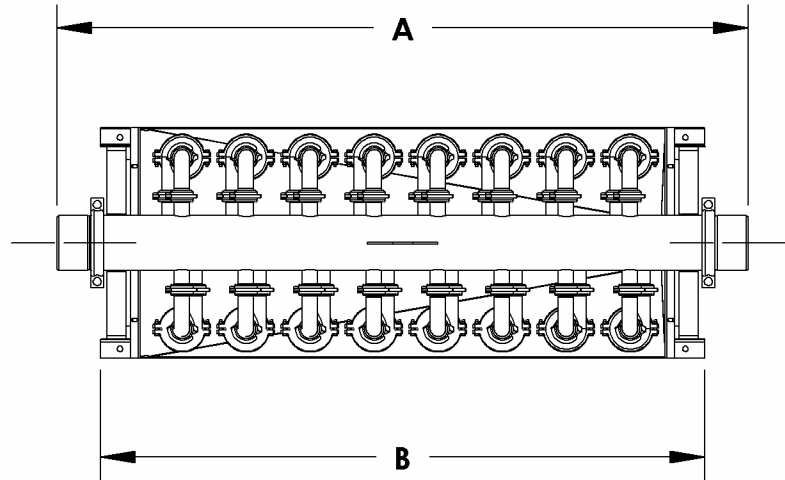

FIG. 1 DESILTER FRONT VIEW



	8-4	10-4	12-4	16-4
A	68.00 [1727.2]	78.00 [1981.2]	88.00 [2235.2]	108.00 [2743.2]
B	54.38 [1387.1]	64.38 [1635.1]	74.38 [1889.1]	94.38 [2397.1]

FIG. 2 DESILTER TOP VIEW

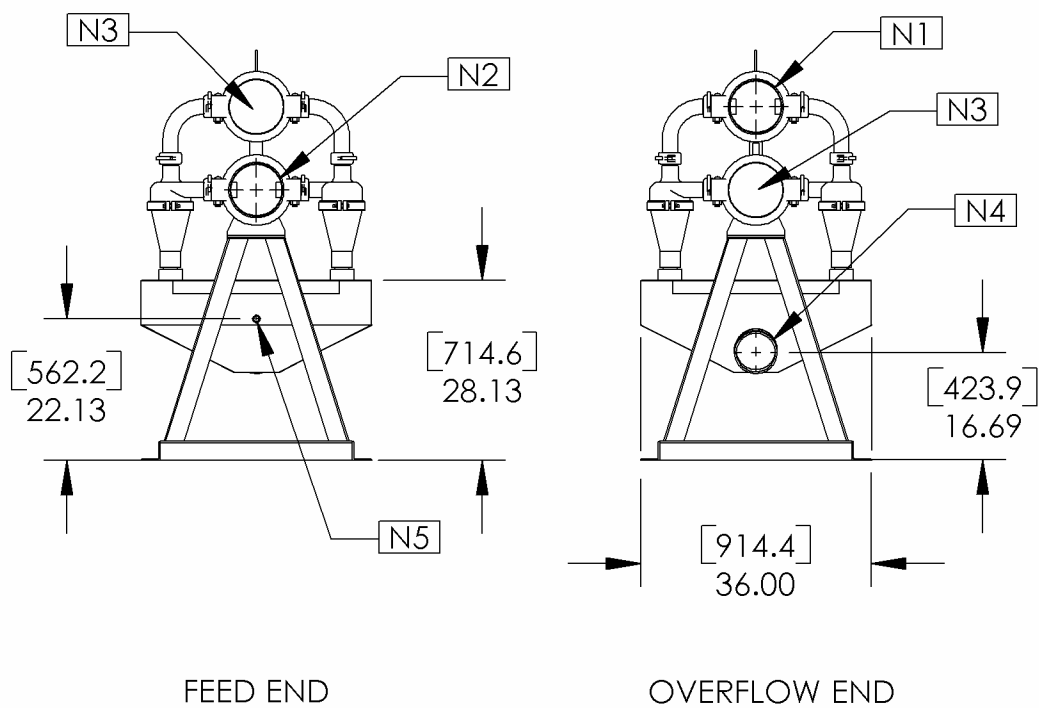
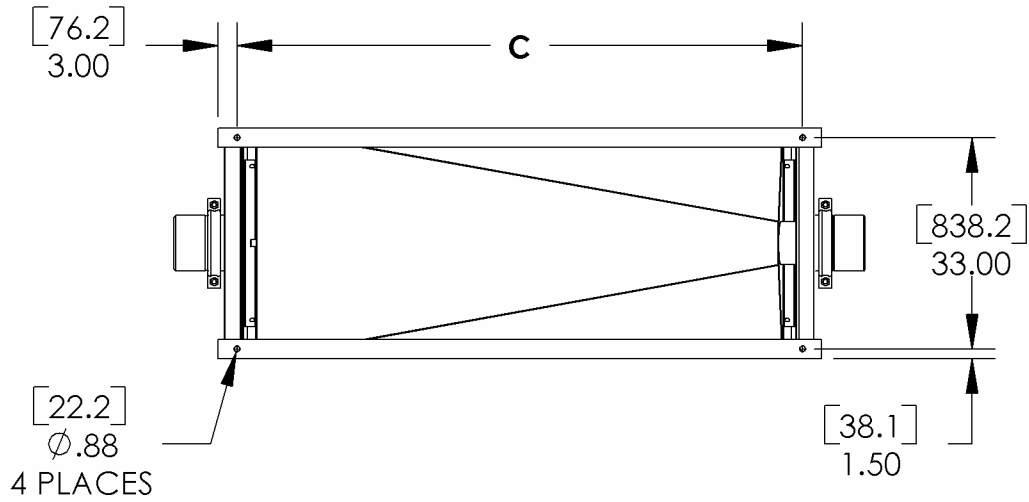

FIG. 3 DESILTER END VIEWS



	8-4	10-4	12-4	16-4
C	48.38 [1228.7]	58.38 [1482.7]	68.38 [1736.7]	88.38 [2244.7]

FIG. 4 DESILTER MOUNTING DETAILS

8-4, 10-4, 12-4			
NO.	SIZE	CONNECTION	DESCRIPTION
N1	6 INCH	WELD	OVERFLOW
N2	6 INCH	WELD	FEED
N3	6 INCH	VICTAULIC	BLANK CAP
N4	6 INCH	VICTAULIC	DISCHARGE
N5	1/2 INCH	NPT	-----

16-4			
NO.	SIZE	CONNECTION	DESCRIPTION
N1	8 INCH	WELD	OVERFLOW
N2	8 INCH	WELD	FEED
N3	8 INCH	VICTAULIC	BLANK CAP
N4	6 INCH	VICTAULIC	DISCHARGE
N5	1/2 INCH	NPT	-----

FIG. 5 NOZZLE SCHEDULE

PART 7 DRAWINGS AND PARTS LISTS

7.1 8-4 DESILTER

ITEM	QTY	PART NO	DESCRIPTION
1	1	-----	PLUG PIPE SQ HD BMI 1/4 NPT 150 LB
2	16	02-EL	ELBOW, 2" POLYURETANE
3	1	02-GAGE	GAGE, 2-1/2" FACE 1/4" NPT, 0-100 PSI
4	16	04-CTX	CONE ASSEMBLY, 4" CTX
5	2	06-NIP	NIPPLE, 6" X 6" SCH 40, VOE X BOE
6	1	10865	WELDMENT, 8-4 HEADER
7	1	10866	WELDMENT, 8-4 TROUGH
8	1	10867	WELDMENT, 8-4 SKID
9	48	2-VIC78	CLAMP, 2" VIC TYPE #78
10	4	6-VIC77	CLAMP, 6" VIC TYPE #77
11	2	6-VICBL	FLANGE, 6" VIC TYPE BLIND

FIG. 6 8-4 PARTS LIST

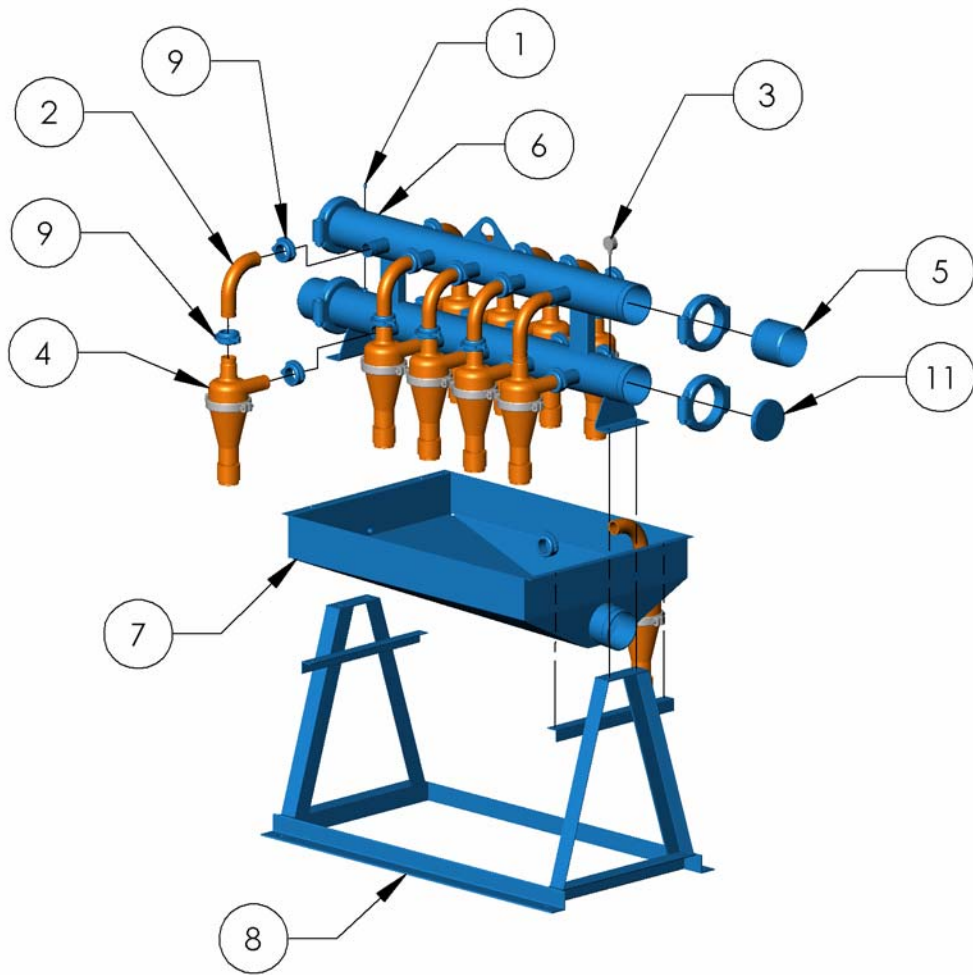

FIG. 7 8-4 ASSEMBLY

7.2 10-4 DESILTER

ITEM	QTY	PART NO	DESCRIPTION
1	1	-----	PLUG PIPE SQ HD BMI 1/4 NPT 150 LB
2	16	02-EL	ELBOW, 2" POLYURETANE
3	1	02-GAGE	GAGE, 2-1/2" FACE 1/4" NPT, 0-100 PSI
4	16	04-CTX	CONE ASSEMBLY, 4" CTX
5	2	06-NIP	NIPPLE, 6" X 6" SCH 40, VOE X BOE
6	1	10862	WELDMENT, 10-4 HEADER
7	1	10863	WELDMENT, 10-4 TROUGH
8	1	10864	WELDMENT, 10-4 SKID
9	48	2-VIC78	CLAMP, 2" VIC TYPE #78
10	4	6-VIC77	CLAMP, 6" VIC TYPE #77
11	2	6-VICBL	FLANGE, 6" VIC TYPE BLIND

FIG. 8 10-4 PARTS LIST

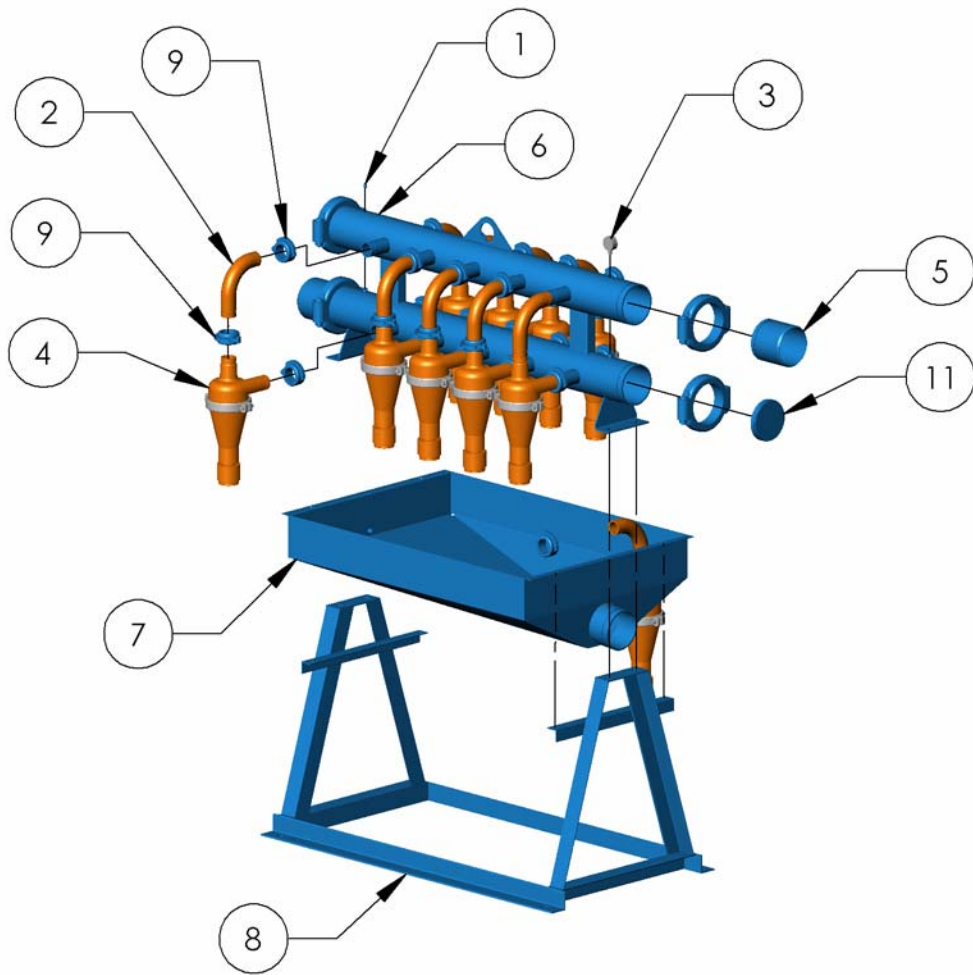

FIG. 9 10-4 ASSEMBLY

7.3 12-4 DESILTER

ITEM	QTY	PART NO	DESCRIPTION
1	1	-----	PLUG PIPE SQ HD BMI 1/4 NPT 150 LB
2	16	02-EL	ELBOW, 2" POLYURETANE
3	1	02-GAGE	GAGE, 2-1/2" FACE 1/4" NPT, 0-100 PSI
4	16	04-CTX	CONE ASSEMBLY, 4" CTX
5	2	06-NIP	NIPPLE, 6" X 6" SCH 40, VOE X BOE
6	1	10859	WELDMENT, 12-4 HEADER
7	1	10860	WELDMENT, 12-4 TROUGH
8	1	10861	WELDMENT, 12-4 SKID
9	48	2-VIC78	CLAMP, 2" VIC TYPE #78
10	4	6-VIC77	CLAMP, 6" VIC TYPE #77
11	2	6-VICBL	FLANGE, 6" VIC TYPE BLIND

FIG. 10 12-4 PARTS LIST

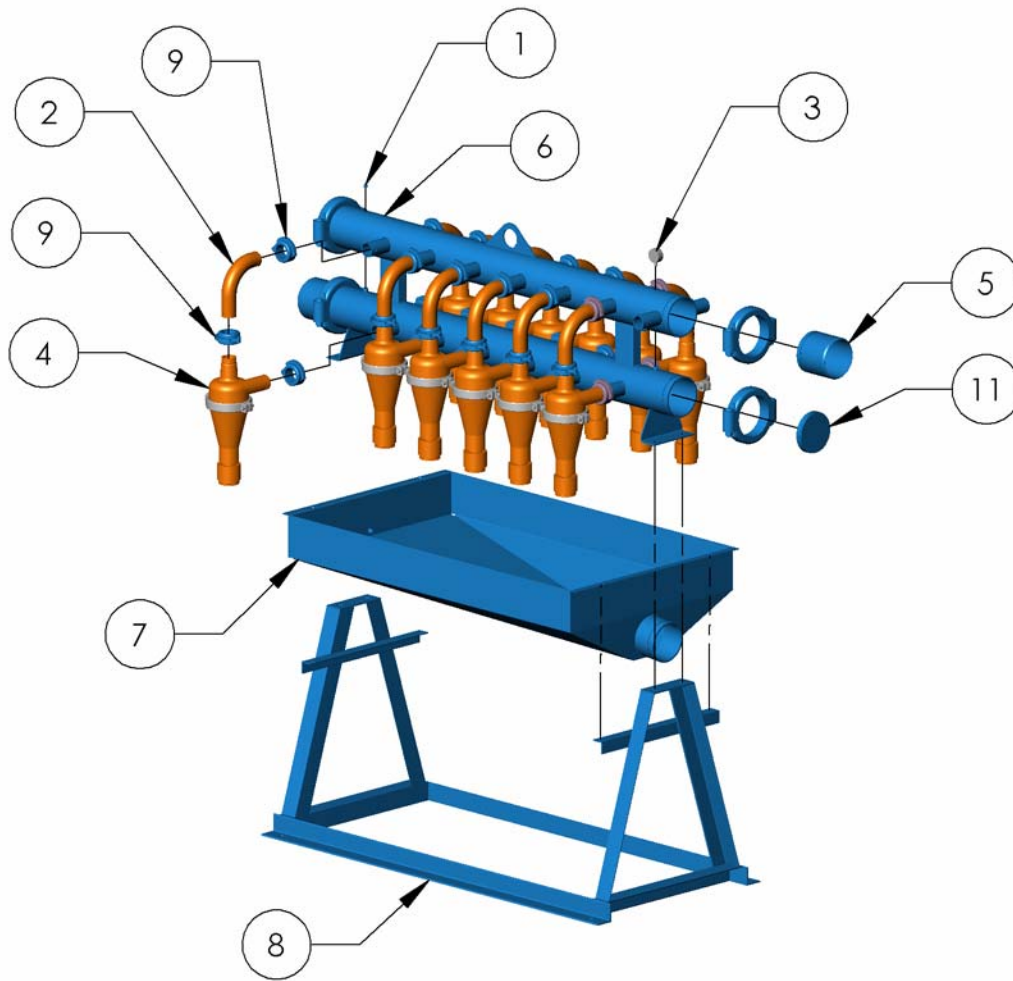

FIG. 11 12-4 ASSEMBLY

7.4 16-4 DESILTER

ITEM	QTY	PART NO	DESCRIPTION
1	1	-----	PLUG PIPE SQ HD BMI 1/4 NPT 150 LB
2	16	02-EL	ELBOW, 2" POLYURETANE
3	1	02-GAGE	GAGE, 2-1/2" FACE 1/4" NPT, 0-100 PSI
4	16	04-CTX	CONE ASSEMBLY, 4" CTX
5	2	08-NIP	NIPPLE, 8" X 6" SCH 40, VOE X BOE
6	1	10838	WELDMENT, 16-4 HEADER
7	1	10839	WELDMENT, 16-4 TROUGH
8	1	10858	WELDMENT, 16-4 SKID
9	48	2-VIC78	CLAMP, 2" VIC TYPE #78
10	4	8-VIC77	CLAMP, 8" VIC TYPE #77
11	2	8-VICBL	FLANGE, 8" VIC TYPE BLIND

FIG. 12 16-4 PARTS LIST

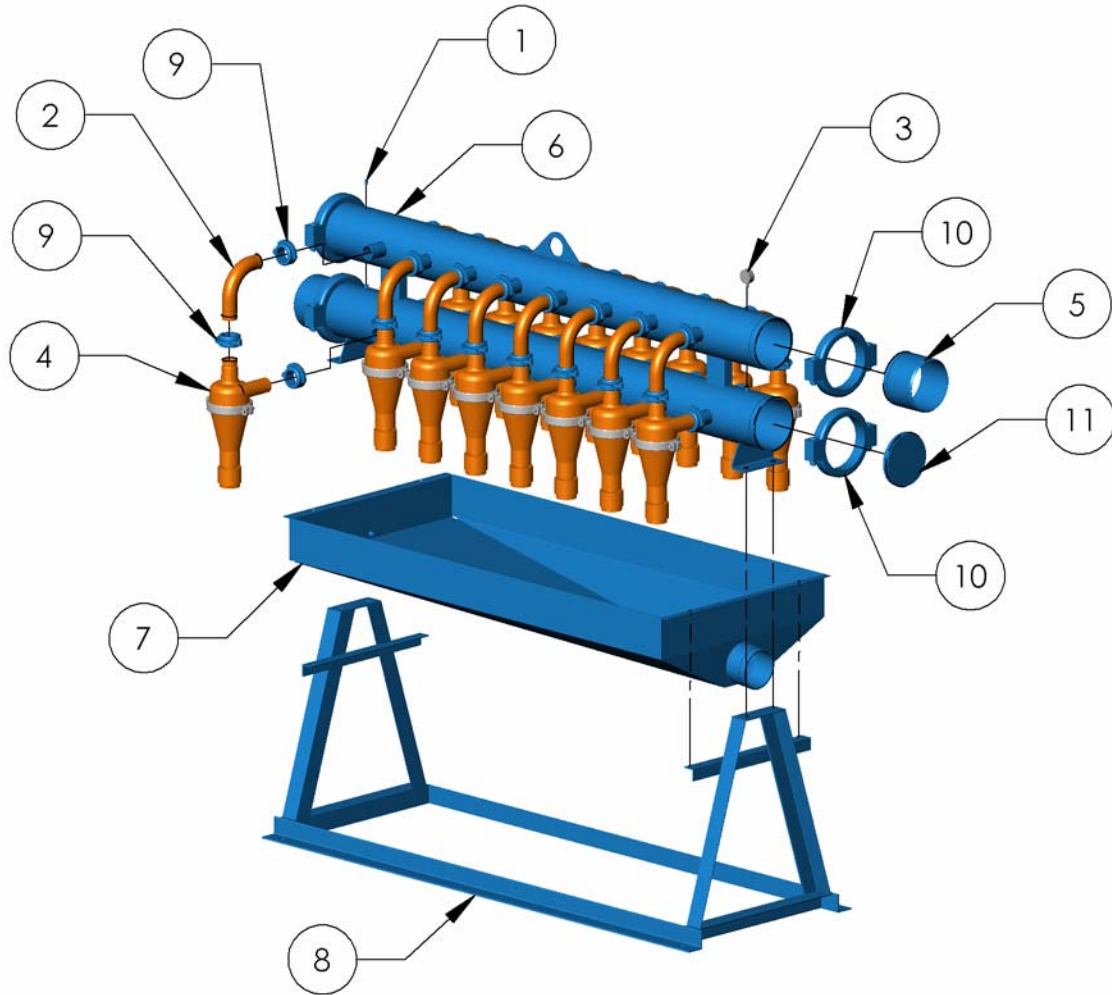

FIG. 13 16-4 ASSEMBLY

PART 8 SPARE PARTS LISTS

1 YR QTY	2 YR QTY	PART NO.	DESCRIPTION
8	16	02-EL	ELBOW, 2" POLYURETANE
1	2	02-GAGE	GAGE, 2-1/2" FACE 1/4" NPT, 0-100 PSI
8	16	04-CTX	CONE ASSEMBLY, 4" CTX
8	16	2-VIC78	CLAMP, 2" VIC TYPE #78
1	2	6-VIC77	CLAMP, 6" VIC TYPE #77
8	16		CONE
8	16		CONE INLET
8	16		CONE ADJUSTABLE NUT
8	16		CONE APEX
8	16		CONE STAINLESS STEEL CLAMP

FIG. 14 8-4 SPARE PARTS

1 YR QTY	2 YR QTY	PART NO.	DESCRIPTION
10	20	02-EL	ELBOW, 2" POLYURETANE
1	2	02-GAGE	GAGE, 2-1/2" FACE 1/4" NPT, 0-100 PSI
10	20	04-CTX	CONE ASSEMBLY, 4" CTX
10	20	2-VIC78	CLAMP, 2" VIC TYPE #78
1	2	6-VIC77	CLAMP, 6" VIC TYPE #77
10	20		CONE
10	20		CONE INLET
10	20		CONE ADJUSTABLE NUT
10	20		CONE APEX
10	20		CONE STAINLESS STEEL CLAMP

FIG. 15 10-4 SPARE PARTS

1 YR QTY	2 YR QTY	PART NO.	DESCRIPTION
12	24	02-EL	ELBOW, 2" POLYURETANE
1	2	02-GAGE	GAGE, 2-1/2" FACE 1/4" NPT, 0-100 PSI
12	24	04-CTX	CONE ASSEMBLY, 4" CTX
12	24	2-VIC78	CLAMP, 2" VIC TYPE #78
1	2	6-VIC77	CLAMP, 6" VIC TYPE #77
12	24		CONE
12	24		CONE INLET
12	24		CONE ADJUSTABLE NUT
12	24		CONE APEX
12	24		CONE STAINLESS STEEL CLAMP

FIG. 16 12-4 SPARE PARTS

1 YR QTY	2 YR QTY	PART NO.	DESCRIPTION
16	32	02-EL	ELBOW, 2" POLYURETANE
1	2	02-GAGE	GAGE, 2-1/2" FACE 1/4" NPT, 0-100 PSI
16	32	04-CTX	CONE ASSEMBLY, 4" CTX
16	32	2-VIC78	CLAMP, 2" VIC TYPE #78
1	2	8-VIC77	CLAMP, 8" VIC TYPE #77
16	32		CONE
16	32		CONE INLET
16	32		CONE ADJUSTABLE NUT
16	32		CONE APEX
16	32		CONE STAINLESS STEEL CLAMP

FIG. 17 16-4 SPARE PARTS

PART 9 TROUBLESHOOTING

Pressure at the feed manifold is too low:

1. New Installation:
 - a. Check whether the pump has an impeller of the size to deliver 90 feet of head with the weight of the mud in use.
 - b. Check whether the pump has an impeller of the size to deliver 90 feet of head with the height of the feed manifold above the mud level.
 - c. Check whether the pump has an impeller of the size to deliver 90 feet of head with the speed being provided for the pump.
 - d. Check whether the pump has an impeller of the size to deliver 90 feet of head with the size and number of cones being supplied.

See APPENDIX A page 381 for impeller sizes.

2. Check the speed of the pump:
 - e. This should be 1750 rpm if an 1800 rpm electric motor.
 - f. This should be 1600 rpm if a diesel engine.
3. Check the length and size of the delivery line from the pump to the manifold. See 3.3 page 10.
4. Check the length and size of the pump suction line. See 1.1 page 9.

-
5. If the pump is piped to supply anything besides the Desilter see that the other things are not taking part of the mud from the pump. Above 500 gpm the pump pressure decreases noticeably with increased volume. The pump impeller should have been chosen for the desired pressure at the expected volume throughput and any extra volume requirement will lower the pressure.
 6. See that the screen, if any, on the suction line is clean.
 7. See that the suction line intake area is not sanded up and that the suction line is clean.
 8. If the pump is belt driven check the belt tension.
 9. See that the shaft packing gland is tight enough that air is not being pulled into the pump through it.
 10. Check for possible air leaks in the suction hose.
 11. Check the amount of lift required:
 - a. For a new installation choose the right impeller for the height from the mud-level to the feed manifold.
 - b. In an installation where normal pressure has been obtained see if the mud level is low. A five foot drop in mud level will cause a loss of feed manifold pressure of about 2-1\2 psi with a 10 lb/gal mud.
 - c. Check the diameter of the impeller. An old impeller may be badly worn and be smaller than its original size.

No underflow or too little underflow.

1. Check the feed pressure. It should be at least 4.2 x Mud Weight in ppg and preferably 4.7 x Mud Weight. This is 45 psi for 9.6 ppg mud.
2. Check the apex for size and see if it has been plugged or partially plugged by trash. If poking a wire up the apex briefly increases the underflow, the problem probably is trash too large to get out – remove the apex and clean it.
3. There may be very little silt in the feed mud.
4. The overflow piping may have enough drop in it to siphon mud from the cone at the expense of the underflow. Install a vacuum breaker in the overflow line or remove the drop in the line.

Underflow discharges as a rope:

1. The apex is too small.
2. The mud viscosity or gel is too high.
3. The feed pressure is too low.

Underflow is too light – less than 2.5 lb/gal (0.29 kg/liter) heavier than the feed mud:

1. See if there is enough silt in the mud to justify running the Desilter.
2. Apex may be several sixes too large. Change to the smallest apex that will allow a spray discharge.

Underflow is heavy – more than 4 lb/gal (0.48 kg/liter) heavier than the feed mud:

1. The mud may have an appreciable sand content. If a Desander is being used ahead of the Desilter check to see that it is installed correctly and is operated correctly. If a Desander is not being used consider getting one. See 3.1 page 7.
2. If the mud is a saturated salt mud the difference between underflow weight and the feed weight should be slightly less than for fresh water mud or between 2.1 lb/gal and (0.25 kf/liter) and 3.0 lf/gal (0.36 lg/liter).
3. If the discharge is roping change to a larger apex valve that will let it spray.

Too large a volume is lost through the underflow:

1. See that the underflow has a spray pattern. A rope underflow does a poor job of desilting and may waste mud unnecessarily.
2. If the underflow weight is at least 2.5 lb/gal (0.29 kg/liter) heavier than the feed mud the underflow is not really excessive if reducing solids content is important. At this underflow weight each gallon of underflow is eliminating about 6 lbs of silt or about 4 times as much silts as a gallon of the feed mud carries.
3. if the underflow weight is less than 2.5 lb/gal (0.29 kg/liter) heavier than the feed the apex valve may be too large for the current silt content.
4. There may be too little silt in the mud to justify desilting.
5. The feed pressure may be too low. Bringing the pressure back to 4.7 x mud weight in ppg should increase the weight of the underflow and reduce the amount of liquid mud in it.

APPENDIX A IMPELLER SIZES

The tables below give a means of calculating proper impeller sizes for good operation in various installations with various mud weights.

IMPELLER SIZES FOR 5X6 PUMPS AT 1600 RPM FOR VARIOUS VOLUME RATES AND PRESSURE HEADS AT PUMPS

		PRESSURE HEAD AT PUMP					
		70 ft	80 ft	90 ft	100 ft	110 ft	120 ft
RATE	500 gpm	9-7/8	9-3/8	9-7/8	10-1/4	10-5/8	11
	750 gpm	9-1/8	9-1/2	10	10-3/8	10-5/8	11-1/8
	900 gpm	9-1/4	9-5/8	10	10-3/8	10-3/4	11-1/4
	1000 gpm	9-3/8	9-3/4	10-1/8	10-1/2	10-7/8	11-1/4
	1250 gpm	9-3/4	10	10-3/8	10-3/4	11	11-1/2
	1500 gpm	10-3/4	10-7/8	11-1/4	10-3/4	12	--

FIG. 18 IMPELLER SIZES FOR 5X6 PUMPS AT 1600 RPM

**IMPELLER SIZES FOR 5X6 PUMPS AT 1750 RPM FOR VARIOUS VOLUME RATES
AND PRESSURE HEADS AT PUMPS**

		PRESSURE HEAD AT PUMP					
		70 ft	80 ft	90 ft	100 ft	110 ft	120 ft
RATE	500 gpm	8-3/8	8-3/4	9-1/8	9-1/2	9-7/8	10-1/4
	750 gpm	8-3/8	8-7/8	9-1/4	9-5/8	10	10-1/4
	900 gpm	8-1/2	9	9-3/8	9-3/4	10	10-3/8
	1000 gpm	8-5/8	9-1/8	9-3/8	9-3/4	10-1/8	10-3/8
	1250 gpm	9-1/8	9-3/8	9-3/4	10-1/8	10-3/8	10-5/8
	1500 gpm	9-5/8	10	10-1/4	10-1/2	10-7/8	11-1/8

FIG. 19 IMPELLER SIZES FOR 5X6 PUMPS AT 1750 RPM

**IMPELLER SIZES FOR 6X8 PUMPS AT 1600 RPM FOR VARIOUS VOLUME RATES
AND PRESSURE HEADS AT PUMPS**

		PRESSURE HEAD AT PUMP					
		70 ft	80 ft	90 ft	100 ft	110 ft	120 ft
RATE	500 gpm	9-3/8	9-3/4	10-1/8	10-1/2	10-7/8	11-3/8
	750 gpm	9-1/2	9-7/8	10-3/8	10-5/8	11	11-1/2
	900 gpm	9-1/2	10	10-3/8	10-3/4	11-1/8	11-1/2
	1000 gpm	9-3/4	10-1/8	10-1/2	10-7/8	11-1/8	11-5/8
	1250 gpm	10-1/8	10-3/8	10-3/4	11-1/8	11-1/2	11-7/8
	1500 gpm	10-3/8	10-3/4	11-1/8	11-3/8	11-3/4	12

FIG. 20 IMPELLER SIZES FOR 6X8 PUMPS AT 1600 RPM

**IMPELLER SIZES FOR 6X8 PUMPS AT 1750 RPM FOR VARIOUS VOLUME RATES
AND PRESSURE HEADS AT PUMPS**

		PRESSURE HEAD AT PUMP					
		70 ft	80 ft	90 ft	100 ft	110 ft	120 ft
RATE	500 gpm	--	9-1/8	9-1/2	9-7/8	10-1/8	10-1/2
	750 gpm	--	9-1/4	9-3/4	10	10-3/8	10-5/8
	900 gpm	9-	9-3/8	9-3/4	10-1/8	10-3/8	10-3/4
	1000 gpm	9-1/8	9-1/2	9-7/8	10-1/8	10-1/2	10-7/8
	1250 gpm	9-3/8	9-3/4	10-1/8	10-3/8	10-3/4	10-7/8
	1500 gpm	9-5/8	10-1/8	10-3/8	10-5/8	11-1/8	--

FIG. 21 IMPELLER SIZES FOR 6X8 PUMPS AT 1750 RPM