

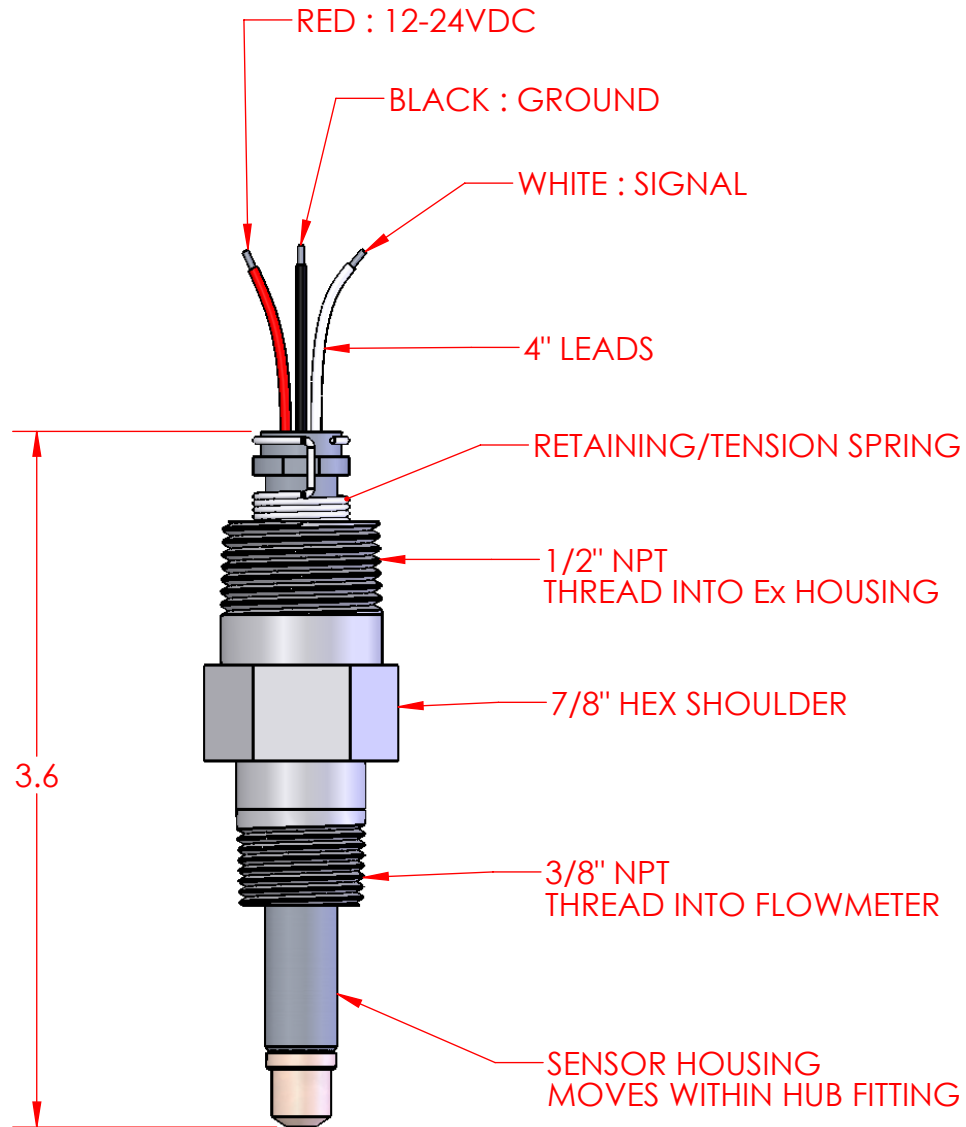

REVISIONS					
REV.	DESCRIPTION	DATE	BY	ECN	APVD
A	INITIAL DRAWING RELEASE	2/13/2006	CH		
B	REVISED COMPANY LOGO	12/07/2011	JP		

# HUB-30-Ex

## PULSE OUTPUT PICKUP



<p>AW-LAKE COMPANY USE ONLY</p> <p>THIS PRINT, INCLUDING THE INFORMATION CONTAINED IN IT IS THE PROPERTY OF AW-LAKE COMPANY. IT IS CONSIDERED PROPRIETARY IN NATURE AND MAY NOT BE USED OR DISCLOSED OUTSIDE OF AW-LAKE COMPANY, EXCEPT UNDER PRIOR WRITTEN AGREEMENT. ANY MODIFICATIONS MADE TO OR COMMENTS WRITTEN ON THIS DRAWING BY UNAUTHORIZED PERSONNEL WILL VOID THIS DRAWING. ALL DIMENSIONS SHOWN ARE SUBJECT TO CHANGE WITHOUT NOTICE.</p>	<p>TOLERANCES UNLESS NOTED ENGLISH</p> <p>.XXXX +/- .0005 .XXX +/- .001 .XX +/- .01</p> <p>FRAC. +/- 1/64 ANG. +/- 1 DEG SURFACE FINISH: 64 MAX</p>	<p>PROJECT NAME: HALL-EX HUB SENSOR</p>	 <p><b>AW-LAKE COMPANY</b> A TASI GROUP COMPANY</p>
		<p>PART DESCRIPTION: HALL-EX HUB SENSOR SPECS</p> <p>MATERIAL:</p> <p>FINISH:</p> <p>HARDENING:</p>	
<p>DRAWING NUMBER: HUBH700</p> <p>PART NUMBER: PU70020</p> <p>DRAWN BY: C. HUSSON</p> <p>PAGE: 1 OF 1</p>	<p>REV: B</p> <p>DATE: 02/13/06</p> <p>SCALE: 1:1</p>		