

## STANDARD TURBINE FLOW METER (TRG SERIES)

### Technical Specifications

#### MULTIPLE FLOW RANGES

.08 TO 5,000 GPM (gal/min)

#### PRESSURE

Working pressure up to 5,000 psi

#### ACCURACY

± 1% of reading or better

#### REPEATABILITY

± 0.1%

#### TURN DOWN RATIO

10:1

#### TEMPERATURE

Fluid temperature of -150° to 450°F

#### FILTRATION

300 microns

#### END CONNECTIONS

NPT

#### MATERIALS OF CONSTRUCTION

- Body & Rotor Support: 316 Stainless Steel
- Rotor: Stainless Steel
- Rotor Shaft: Tungsten Carbide



*Turbine meter shown with Mag-PB sensor*

### Benefits

#### RUGGED AND COST-EFFECTIVE

The sturdy construction of this turbine flow meter means high performance and longer service life at an affordable price.

#### INDUSTRY STANDARD

The TRG Series flow meter comes with a standard NPT end connection for universal applications.

#### VERSATILE

This meter is capable of measuring flow in line sizes from 1/2" to 10".

#### ELECTRONIC INTEGRATION

This meter can provide displayed flow rate, totalization, current or voltage outputs through a variety of compatible electronics.

#### SIMPLIFIED MAINTENANCE

The TRG Series was designed with only one moving part for easy cleaning and maintenance.

# STANDARD TURBINE FLOW METER (TRG SERIES)



## Meter Specifications

Part Number	Range (gal/min)	K-Factor * (Pulses/ gal)	Porting	Filtration (micron)	Pressure Rating (psi)	Weight (lbs)
TRG-11.250-5	0.08 to 0.4	125,000	1/2" Male NPT	100	5,000	0.75
TRG-11.300-5	0.13 to 1.06	91,500	1/2" Male NPT	100	5,000	0.75
TRG-11.375-5	0.3 to 3	48,000	1/2" Male NPT	100	5,000	0.75
TRG-11.500-5	0.9 to 9	15,000	1/2" Male NPT	100	5,000	0.75
TRG-11.750-5	1.6 to 16	10,500	1/2" Male NPT	300	5,000	0.75
TRG-11.750	1.6 to 16	10,500	1" Male NPT	300	5,000	1.25
TRG-11.875	3.2 to 32	1,450	1" Male NPT	300	5,000	1.50
TRG-1110	5.3 to 53	800	1-1/2" Male NPT	300	5,000	2.50
TRG-1120L	13 to 200	400	2" Male NPT	300	5,000	3.25

\* K-Factors given are averaged. A calibration sheet accompanies every meter sold.

## Meter Dimensions

Part Number	A	B	C
TRG-11.250-5	3.00"	1.35"	1.20"
TRG-11.300-5	3.00"	1.35"	1.20"
TRG-11.375-5	3.00"	1.35"	1.20"
TRG-11.500-5	3.00"	1.35"	1.20"
TRG-11.750-5	3.00"	1.35"	1.20"
TRG-11.750	3.00"	1.55"	1.40"
TRG-11.875	3.00"	1.55"	1.40"
TRG-1110	3.00"	2.15"	1.95"
TRG-1120L	4.00"	2.70"	2.55"

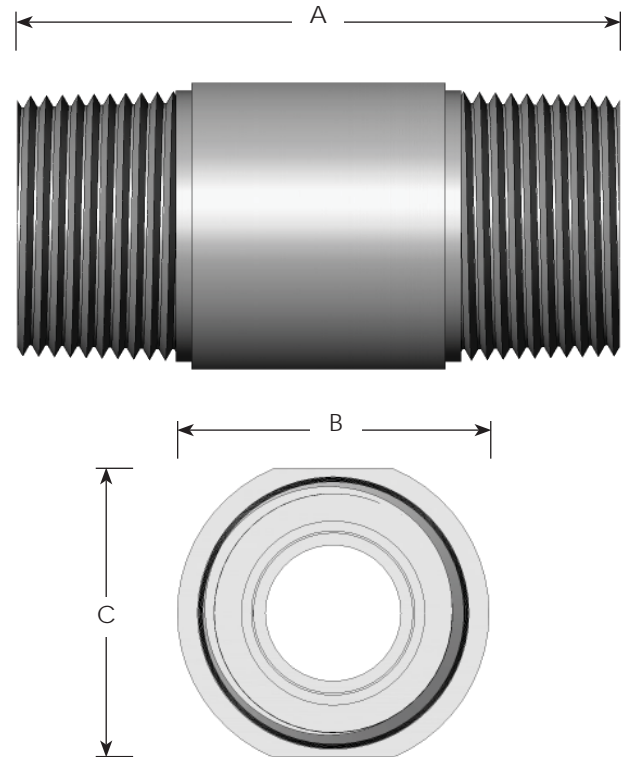

## Compatible Electronics

Model	Sensor Type	Temp (°F)
MAG-PB	Pulse Sensor - <i>No Amplifier Required</i>	40 to 185
FIP-4HS	4-20 mA Output Sensor	-40 to 185
<b>Meter Mounted Displays:</b>		
RT-Ex 10A	Battery-Powered Monitor	0 to 140
RT-Ex 15A	15-24 VDC Powered Monitor	0 to 140

\* For additional sensors available, contact factory.

### Contact Sabre Turbine Meters:

toll-free: 800-850-6110

fax: 262-884-9810

email: [sabreinfo@aw-lake.com](mailto:sabreinfo@aw-lake.com)

website: [www.sabreflow.com](http://www.sabreflow.com)