

# Hormann America Success Stories

## City

### City of Artesia, New Mexico

#### Citywide Siren System

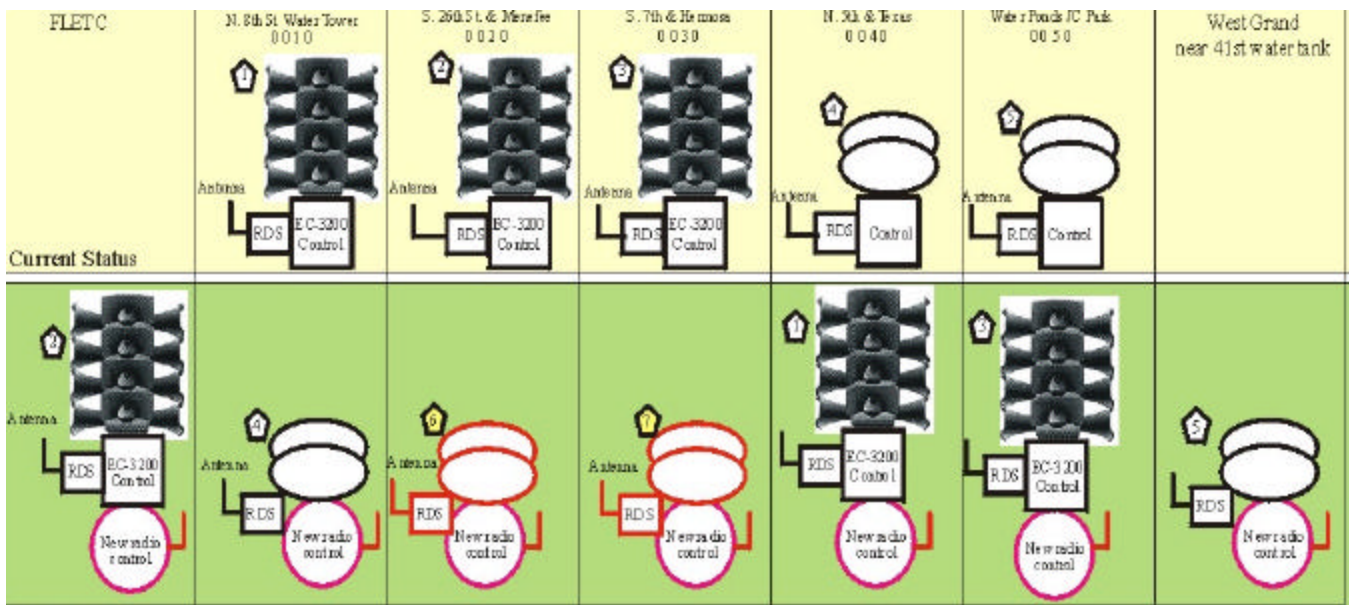

**Artesia, New Mexico community warning notification system:** The city of Artesia, New Mexico need to alert and notify the public of emergencies that may be harmful to their well-being; • Notify appropriate emergency response personnel • Provide on-going updates about the incident and additional protective measures that may be required.

**Solution Selected:** *Hormann America Outdoor Warning with EAS System*. The System consists of seven (7) outdoor warning sirens, Central Station Control, RDS sub carrier activation and EAS override for 2 radio stations. The system was upgraded in 2001, adding control features to enable the police to sound the sirens from their patrol cars.

**Client Comment:** We appreciate Hormann America help in maintaining our existing Community Warning System and then upgrading the Community Warning System. We are thrilled with our new Community Warning System. Many thanks, Artesia Police & Fire Department, Artesia, New Mexico.