

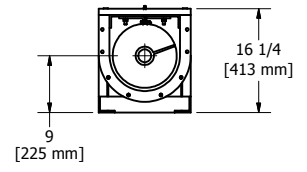

PARTS LIST			
ITEM	QTY	PART NUMBER	DESCRIPTION
1	1	10H61r	SCREW, 10" X 10' FOR 2" SHAFT
2	1	CTF107	TROUGH, 10" X 10'
3	1	10-TG	10" TROUGH GASKET
4	2	HHCS.625-11X3.75	HHCS, 5/8-11 X 3.75, GRADE 5, ZINC PL
5	2	NUT .625-11	NUT, 5/8-11, ZINC PL
6	1	10-FRP	FRP GRATE, 10" X 10'
7	1	CC2	COUPLING SHAFT, 2"
8	6	FRPCCA	FRP CONVEYOR CLAMP ASSEMBLY
9	8	.375 TCA	TROUGH CONNECTOR ASSEMBLY
10	1	10-HB	HANGER BEARING ASSEMBLY

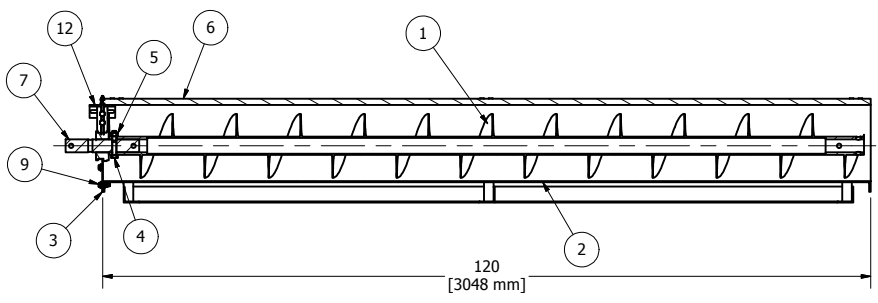
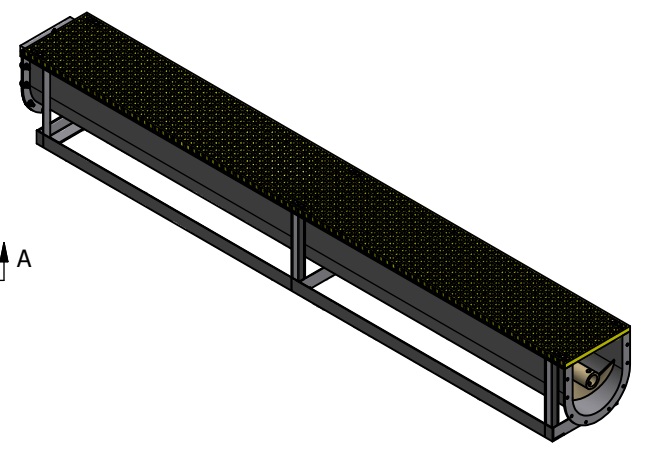
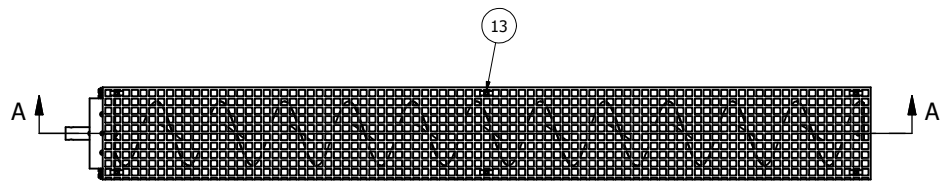

SECTION A-A

DRAWN	10/5/2010	 7519 Prairie Oak Dr Houston, TX 77086 281-893-4774 281-893-1027 FAX		
CHECKED				
QA				
MFG				
APPROVED		TITLE <b>GENERAL ARRANGEMENT, 10" X 10' SCREW          CONVEYOR MID SECTION WITH FRP COVER          AND TROUGH FRAME</b>		
		SIZE <b>C</b>	DWG NO <b>GA11797</b>	REV
		SCALE		SHEET 1 OF 1