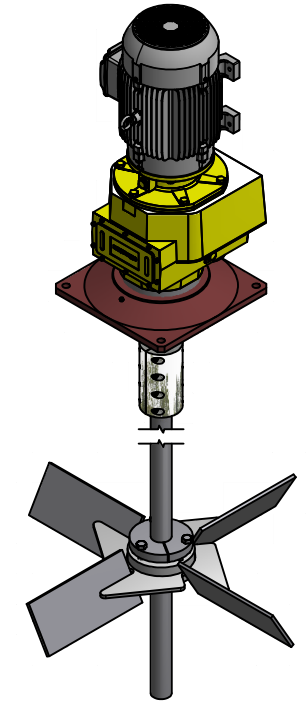
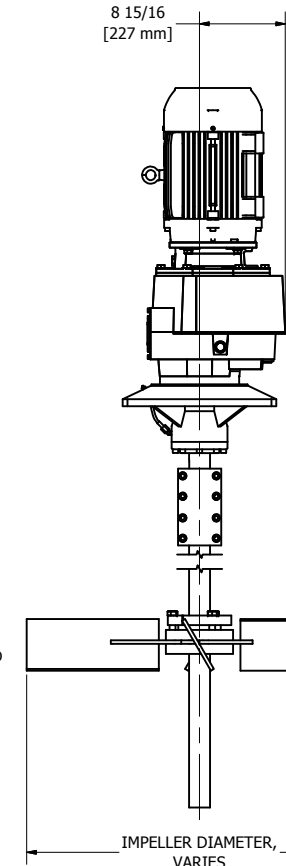
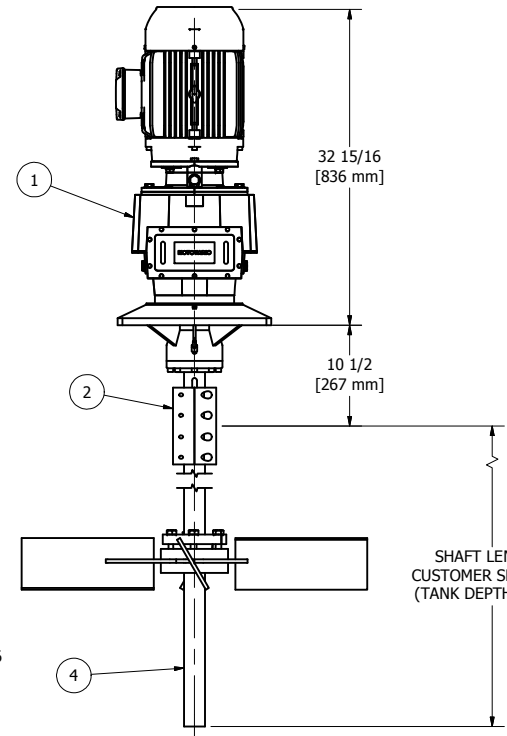
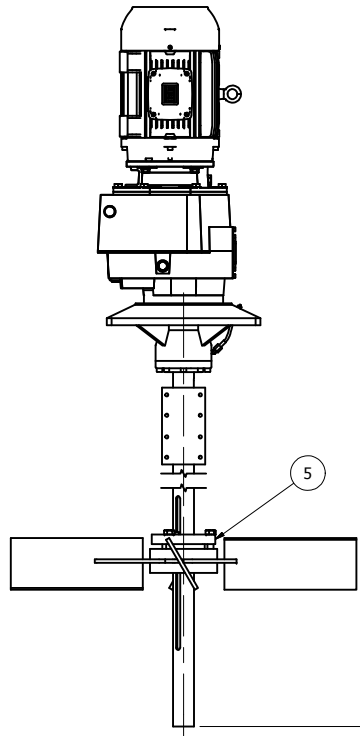
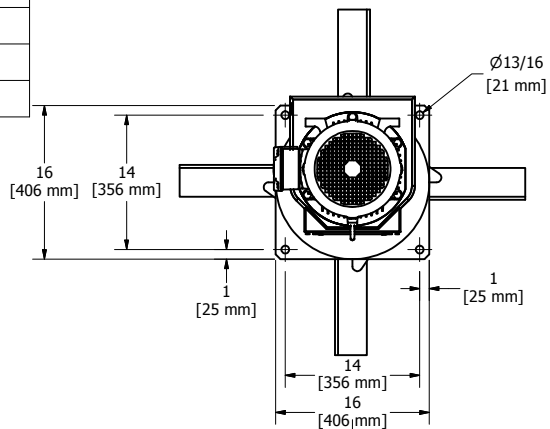

TABLE 1: DRIVE OPTIONS	
PART NUMBER	DESCRIPTION
M2A10-460	10 HP MAX 2000 DRIVE WITH 10 HP 1750 RPM, 215TC FRAME, 230/460 V, 60 HZ, TEXP MOTOR.
M2A10-575	10 HP MAX 2000 DRIVE WITH 10 HP 1750 RPM, 215TC FRAME, 575 V, 60 HZ, TEXP MOTOR.
M2A07-380	7.5 MAX 2000 DRIVE WITH 7.5 HP 1450 RPM, 215TC FRAME, 190/380 V, 50 HZ, TEXP MOTOR.

TABLE 2: IMPELLER OPTIONS	
PART NUMBER	DESCRIPTION
32CI	32" DIAMETER CANTED IMPELLER
34CI	34" DIAMETER CANTED IMPELLER
36CI	36" DIAMETER CANTED IMPELLER
38CI	38" DIAMETER CANTED IMPELLER



**NOTES:**  
 1. APPROXIMATE DRIVE WEIGHT IS 570 LB (259 KG).

PARTS LIST			
ITEM	QTY	PART NUMBER	DESCRIPTION
1	1	-	SEE TABLE 1
2	1	2.1875CTX	CLAMP FOR 2 3/16" SHAFT
3	1	-	SEE TABLE 2
4	1	2.1875-S	BAR, ROUND 2 3/16" DIA. LENGTH SPECIFIED BY CUSTOMER
5	1	2.1875-F	BUSHING, 2 3/16" BORE QD TYPE F

DRAWN	LG	7/27/2010
CHECKED		
QA		
MFG		
APPROVED		

 7519 Prairie Oak Dr Houston, TX 77086 281-893-4774 281-893-1027 FAX		
TITLE		
GENERAL ARRANGEMENT, M2A10-V AT 60 HZ AND M2A07-V AT 50 HZ		
SIZE	DWG NO	REV
C	GA11052	
SCALE	SHEET 1 OF 1	