

VACUUM PUMP

60 1/16  
[1526 mm]

56  
[1422 mm]

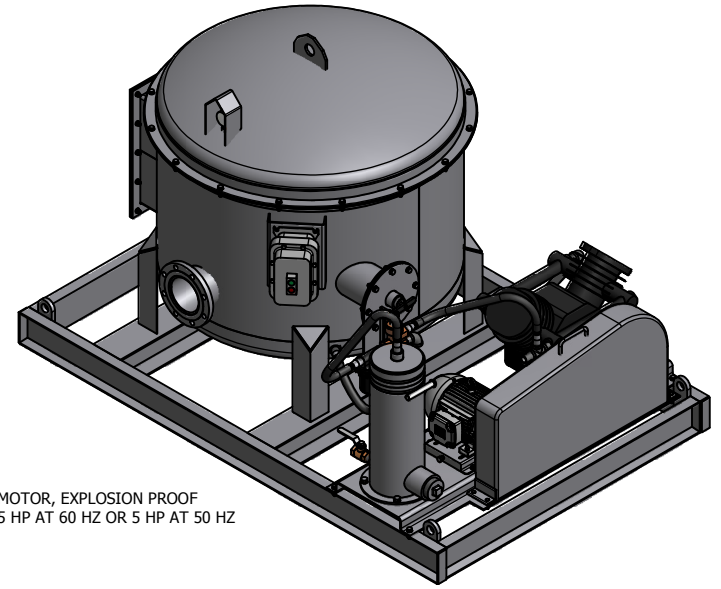

MOTOR, EXPLOSION PROOF  
5 HP AT 60 HZ OR 5 HP AT 50 HZ

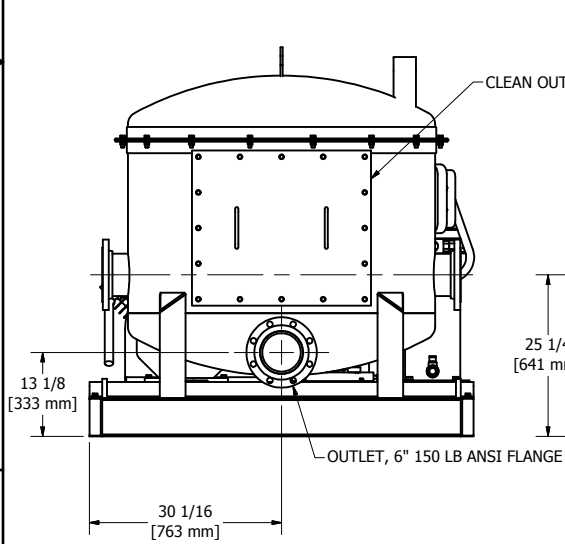

13 1/8  
[333 mm]

30 1/16  
[763 mm]

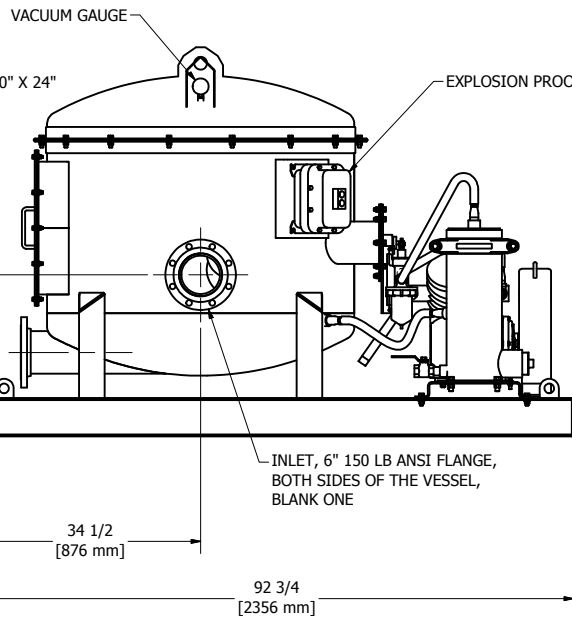

25 1/4  
[641 mm]

34 1/2  
[876 mm]

92 3/4  
[2356 mm]

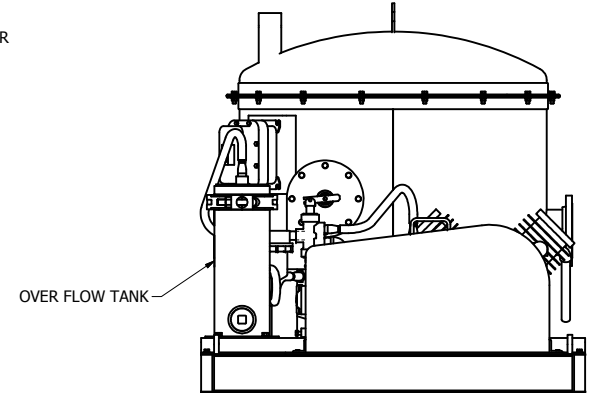

OVER FLOW TANK

**NOTES:**

1. APPROXIMATE DRY WEIGHT IS 2375 LB (1080 KG).

DRAWN	10/11/2010	 7519 Prairie Oak Dr Houston, TX 77086 281-893-4774 281-893-1027 FAX
LG		
CHECKED		TITLE
QA		GENERAL ARRANGEMENT, VAK 500 VACUUM DEGASSER
MFG		SIZE
APPROVED		C
		DWG NO
		GA11127
		SCALE
		SHEET 1 OF 1