

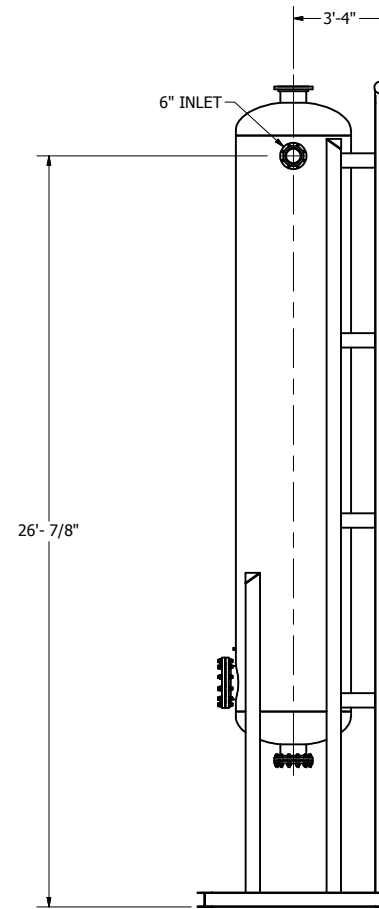

SECTION A-A

**NOTES:**

1. APPROXIMATE WT IS 9850 LB.

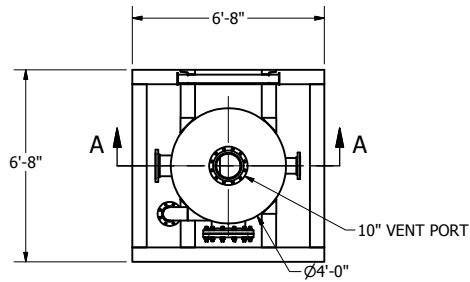

DRAWN	LG	9/22/2010	 7519 Prairie Oak Dr Houston, TX 77086 281-593-4774 281-593-1027 FAX	
CHECKED				
QA			TITLE	
MFG			GENERAL ARRANGEMENT, 4' X 20' MUD GAS SEPARATOR	
APPROVED			SIZE	DWG NO
			C	GA11775
			SCALE	REV