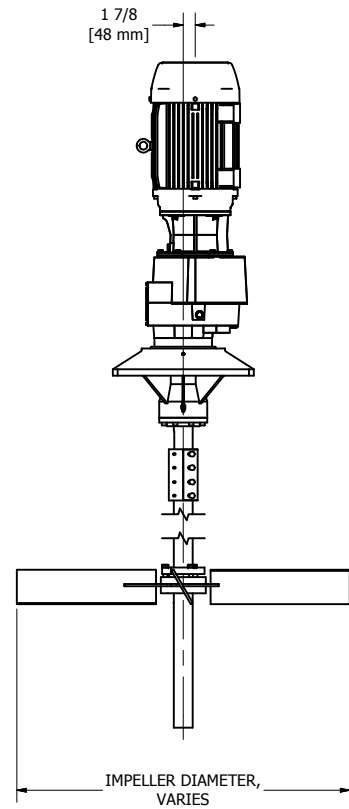
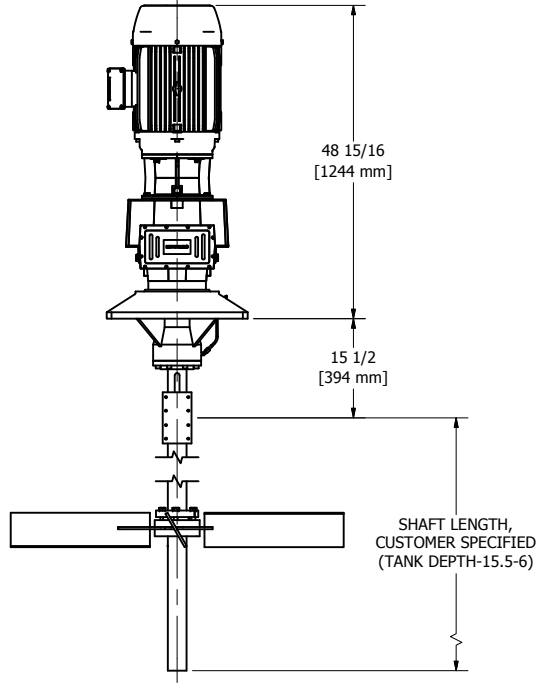
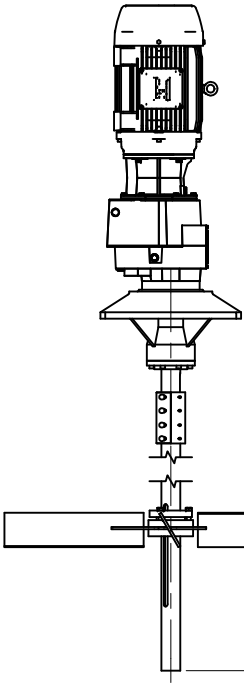
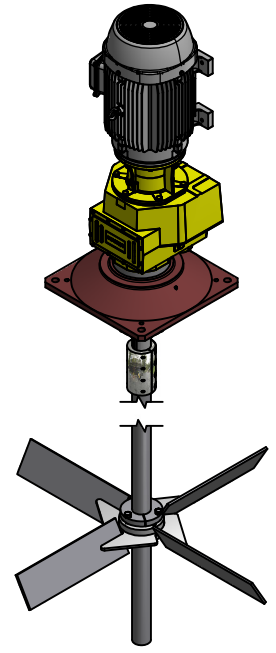
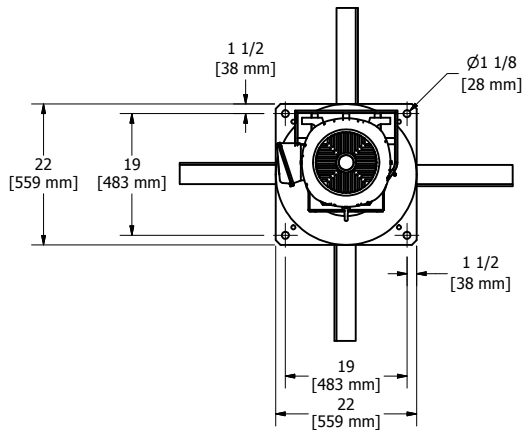

TABLE 1: DRIVE OPTIONS	
PART NUMBER	DESCRIPTION
M2A30V-460	30 HP VERTICAL MAX 2000 DRIVE WITH 30 HP 1750 RPM, 286TC FRAME, 230/460 V, 60 HZ, TEXP MOTOR.
M2A30V-575	30 HP VERTICAL MAX 2000 DRIVE WITH 30 HP 1750 RPM, 286TC FRAME, 575 V, 60 HZ, TEXP MOTOR.
M2A25V-380	25 HP VERTICAL MAX 2000 DRIVE WITH 25 HP 1450 RPM, 286TC FRAME, 190/380 V, 50 HZ, TEXP MOTOR.

TABLE 2: IMPELLER OPTIONS	
PART NUMBER	DESCRIPTION
42CI	42" DIAMETER CANTED IMPELLER
44CI	44" DIAMETER CANTED IMPELLER
48CI	48" DIAMETER CANTED IMPELLER
52CI	52" DIAMETER CANTED IMPELLER



NOTES:
 1. APPROXIMATE DRIVE WEIGHT IS 1086 LB (494 KG).

PARTS LIST			
ITEM	QTY	PART NUMBER	DESCRIPTION
1	1	-	SEE TABLE 1
2	1	2.9375CTX	CLAMP FOR 2 15/16" SHAFT
3	1	2.9375-S	BAR, ROUND 2 15/16" DIA. CUSTOMER TO SPECIFY LENGTH
4	1	TYPE F 2.9375	BUSHING, 2 15/16" BORE QD TYPE F
5	1	-	SEE TABLE 2

DRAWN	LG	7/27/2010
CHECKED		
QA		
MFG		
APPROVED		

 7519 Prairie Oak Dr
 Houston, TX 77086
 281-893-4774
 281-893-1027 FAX

GENERAL ARRANGEMENT, M2A30V AT 60 HZ AND M2A25V AT 50 HZ

SIZE	DWG NO	REV
C	GA11270	
SCALE	SHEET 1 OF 1	