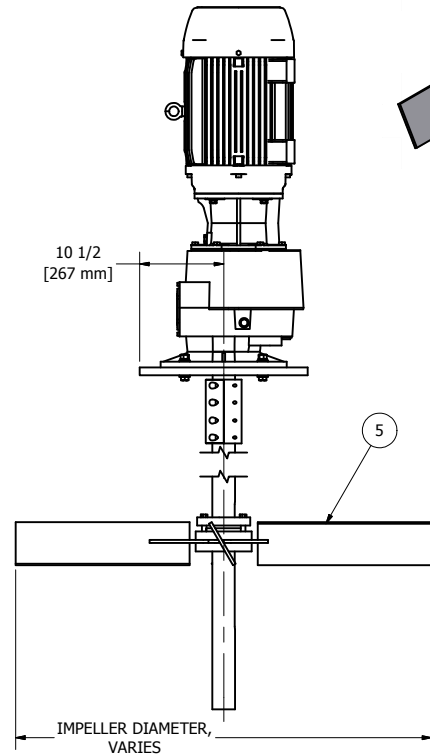
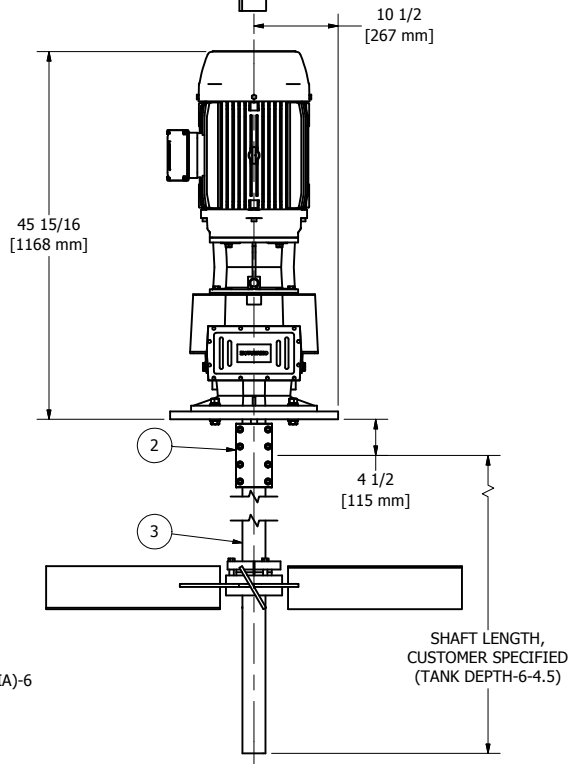
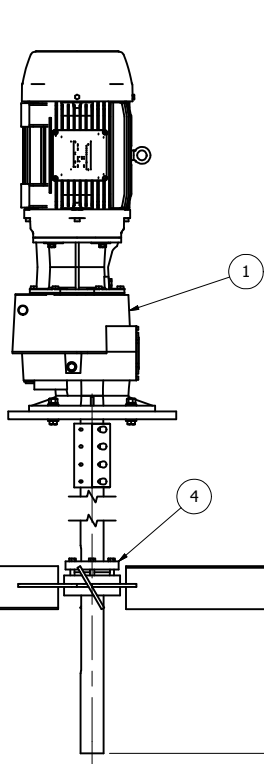
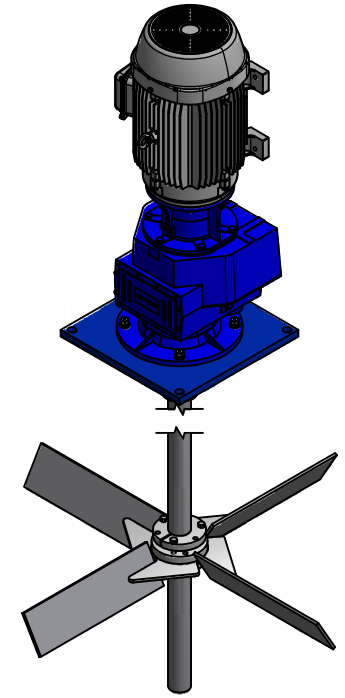
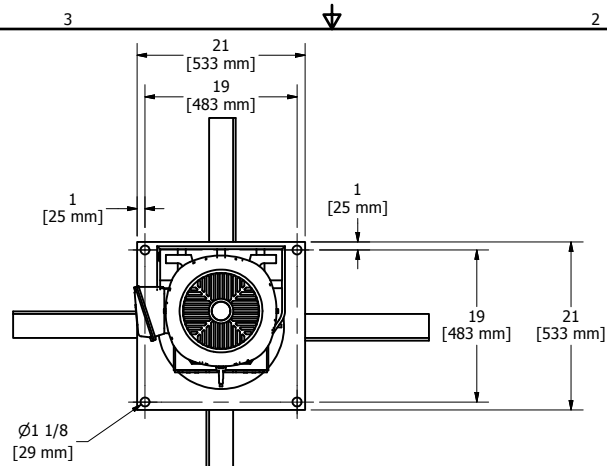

TABLE 1: DRIVE OPTIONS	
PART NUMBER	DESCRIPTION
LPM2A30V-460	30 HP VERTICAL LOW PROFILE DRIVE WITH 30 HP 1750 RPM, 286TC FRAME, 230/460 V, 60 HZ, TEXP MOTOR.
LPM2A30V-575	30 HP VERTICAL LOW PROFILE DRIVE WITH 30 HP 1750 RPM, 286TC FRAME, 575 V, 60 HZ, TEXP MOTOR.
LPM2A25V-380	25 HP VERTICAL LOW PROFILE DRIVE WITH 25 HP 1450 RPM, 286TC FRAME, 190/380 V, 50 HZ, TEXP MOTOR.

TABLE 2: IMPELLER OPTIONS	
PART NUMBER	DESCRIPTION
44CI	44" DIAMETER CANTED IMPELLER
48CI	48" DIAMETER CANTED IMPELLER
52CI	52" DIAMETER CANTED IMPELLER



NOTES:

1. APPROXIMATE DRIVE WEIGHT IS 866 LB (394 KG).

PARTS LIST			
ITEM	QTY	PART NUMBER	DESCRIPTION
1	1	-	SEE TABLE 1
2	1	2.875CTX	CLAMP FOR 2 7/8" SHAFT
3	1	2.875-S	BAR, ROUND 2 7/8" DIA. CUSTOMER TO SPECIFY LENGTH
4	1	TYPE F 2.875	BUSHING, 2 7/8" BORE QD TYPE F
5	1	-	SEE TABLE 2

DRAWN	7/27/2010
LG	
CHECKED	
QA	
MFG	
APPROVED	

 7519 Prairie Oak Dr Houston, TX 77086 281-893-4774 281-893-1027 FAX		TITLE	
		GENERAL ARRANGEMENT, M2A30 AT 60 HZ AND M2A25 AT 50 HZ	
SIZE	DWG NO	REV	
C	GA11807 LPM2A30-V		
SCALE	SHEET 1 OF 1		