

Instruction 51-1047
4-8-06

Copyright © 2003, 2004, 2006
by S&S Cycle, Inc.

All rights reserved.
Printed in the U.S.A.

S&S® Cycle, Inc.

235 Causeway Blvd.
La Crosse, Wisconsin 54603
Phone: 608-627-1497 • Fax: 608-627-1488
Technical Service Phone: 608-627-TECH (8324)
Technical Service Email: sstech@sscycle.com
Website: www.sscycle.com



Because every industry has a leader

Installation Instructions: S&S® Gear Drive Cams for Harley-Davidson® Twin Cam 88® Engines

DISCLAIMER:

S&S parts are designed for high performance, off road, racing applications and are intended for the very experienced rider only. The installation of S&S parts may void or adversely effect your factory warranty. In addition such installation and use may violate certain federal, state, and local laws, rules and ordinances as well as other laws when used on motor vehicles used on public highways, especially in states where pollution laws may apply. Always check federal, state, and local laws before modifying your motorcycle. It is the sole and exclusive responsibility of the user to determine the suitability of the product for his or her use, and the user shall assume all legal, personal injury risk and liability and all other obligations, duties, and risks associated therewith.

The words Harley®, Harley-Davidson®, H-D®, Sportster®, Evolution®, and all H-D part numbers and model designations are used in reference only. S&S Cycle is not associated with Harley-Davidson, Inc.

SAFE INSTALLATION AND OPERATION RULES:

Before installing your new S&S part it is your responsibility to read and follow the installation and maintenance procedures in these instructions and follow the basic rules below for your personal safety.

- Gasoline is extremely flammable and explosive under certain conditions and toxic when breathed. Do not smoke. Perform installation in a well ventilated area away from open flames or sparks.
- If motorcycle has been running, wait until engine and exhaust pipes have cooled down to avoid getting burned before performing any installation steps.
- Before performing any installation steps disconnect battery to eliminate potential sparks and inadvertent engagement of starter while working on electrical components.
- Read instructions thoroughly and carefully so all procedures are completely understood before performing any installation steps. Contact S&S with any questions you may have if any steps are unclear or any abnormalities occur during installation or operation of motorcycle with a S&S part on it.
- Consult an appropriate service manual for your motorcycle for correct disassembly and reassembly procedures for any parts that need to be removed to facilitate installation.
- Use good judgement when performing installation and operating motorcycle. Good judgement begins with a clear head. Don't let alcohol, drugs or fatigue impair your judgement. Start installation when you are fresh.
- Be sure all federal, state and local laws are obeyed with the installation.
- For optimum performance and safety and to minimize potential damage to carb or other components, use all mounting hardware that is provided and follow all installation instructions.
- Motorcycle exhaust fumes are toxic and poisonous and must not be breathed. Run motorcycle in a well ventilated area where fumes can dissipate.

IMPORTANT NOTICE:

Statements in this instruction sheet preceded by the following words are of special significance.



WARNING

Means there is the possibility of injury to yourself or others.



CAUTION

Means there is the possibility of damage to the part or motorcycle.

NOTE

Other information of particular importance has been placed in italic type.

S&S recommends you take special notice of these items.

WARRANTY:

All S&S parts are guaranteed to the original purchaser to be free of manufacturing defects in materials and workmanship for a period of twelve (12) months from the date of purchase. Merchandise that fails to conform to these conditions will be repaired or replaced at S&S's option if the parts are returned to us by the purchaser within the 12 month warranty period or within 10 days thereafter.

In the event warranty service is required, the original purchaser must call or write S&S immediately with the problem. Some problems can be rectified by a telephone call and need no further course of action.

A part that is suspect of being defective must not be replaced by a Dealer without prior authorization from S&S. If it is deemed necessary for S&S to make an evaluation to determine whether the part was defective, a return authorization number must be obtained from S&S. The parts must be packaged properly so as to not cause further damage and be returned prepaid to S&S with a copy of the original invoice of purchase and a detailed letter outlining the nature of the problem, how the part was used and the circumstances at the time of failure. If after an evaluation has been made by S&S and the part was found to be defective, repair, replacement or refund will be granted.

ADDITIONAL WARRANTY PROVISIONS:

- (1) S&S shall have no obligation in the event an S&S part is modified by any other person or organization.
- (2) S&S shall have no obligation if an S&S part becomes defective in whole or in part as a result of improper installation, improper maintenance, improper use, abnormal operation, or any other misuse or mistreatment of the S&S part.
- (3) S&S shall not be liable for any consequential or incidental damages resulting from the failure of an S&S part, the breach of any warranties, the failure to deliver, delay in delivery, delivery in non-conforming condition, or for any other breach of contract or duty between S&S and a customer.
- (4) S&S parts are designed exclusively for use in Harley-Davidson® and other American v-twin motorcycles. S&S shall have no warranty or liability obligation if an S&S part is used in any other application.

| Specification for S&S® Gear Drive Camshaft for Harley-Davidson® Twin Cam 88® Engines | | | | | | | | | |
|--|---------------------------|-----------|----------------|---------|------------|------------|---------|------------|---------|
| Cam Name | Valve Timing Open / Close | | Valve Duration | | Valve Lift | Centerline | | Lift @ TDC | |
| | Intake | Exhaust | Intake | Exhaust | | Intake | Exhaust | Intake | Exhaust |
| 510G | 20° / 38° | 52° / 20° | 238° | 252° | .510" | 99° | 106° | .187" | .179" |
| 570G | 20° / 40° | 55° / 20° | 240° | 255° | .570" | 100° | 107.5° | .187" | .179" |
| 585G | 20° / 45° | 60° / 20° | 245° | 260° | .585" | 102.5° | 110° | .186" | .179" |
| 625G | 20° / 55° | 60° / 20° | 255° | 260° | .625" | 107.5° | 110° | .189" | .184" |
| 640G | 25° / 60° | 65° / 25° | 265° | 270° | .540" | 107.5° | 110° | .228" | .214" |

Chart 1

INTRODUCTION

The S&S® gear drive cams offer many advantages over the original cam chain drive system:

- Reduced maintenance. There are no chain guides or shoes to wear or replace and no debris from wearing guides or shoes in your engine oil.
- Consistent cam timing. Cam gears are keyed with a light press fit. Chain and tensioner induced variations are no longer a problem.
- Eliminating the chains and tensioners eliminates excessive side loading of cam bearings.
- Critical sprocket alignment is unnecessary. Use of precision machined spacers is eliminated.
- Maintain accurate valve timing when using high performance valve springs with higher spring forces.
- Higher cam lifts can be used without decreasing cam base circle. Gear driven rear cam rotates in opposite direction from chain driven cam. Lobes on front and rear cams never point toward each other, allowing increased lobe height.

COMPATABILITY NOTES:

- S&S Gear Drive Cams are not compatible with camshafts designed for the stock chain cam drive. S&S Gear Drive Cams must be used with S&S gear drive camshafts.
- Except for the 510G, the gear driven camshaft kits are not compatible with stock pushrods or valve springs. S&S adjustable pushrod kit 93-5095 is recommended for engines with stock length cylinders. Longer pushrods are available for engines with longer than stock cylinders. See the S&S catalog for pushrods and valve springs.
- S&S Camshaft Installation Kit 33-5163 is strongly recommended when installing S&S gear drive cams. The kit includes gaskets and bearings required for installation, but does not include oil pump O-rings.

⚠ CAUTION

All S&S gear drive cams except for the 510G require that the stock valve springs be replaced with high lift spring kits. Some high lift spring kits require clearance checks and may require cylinder head modifications to prevent contact between top collar and valve seal, and to achieve correct installed height. See the instructions with your spring kit for exact specifications.

- When using S&S gear drive cam shafts with stock Harley-Davidson® pistons, valve-to-piston clearance may need to be checked. See Chart 2.

- If stock Harley-Davidson® heads are decked, valve to piston clearance must be checked. If insufficient clearance is found, valve pockets must be modified.
- When using S&S pistons with S&S heads which are unmodified or have been decked no more than .062", no additional valve to piston clearancing will be required.

| Valve to Piston Clearance Chart Stock Harley-Davidson® Pistons* | | | | | |
|--|------|------|------|------|------|
| Head Style | Cam | | | | |
| | 510G | 570G | 585G | 625G | 640G |
| Stock | OK | OK | OK | OK | 1 |
| S&S 79cc | OK | OK | OK | 1 | 1 |
| S&S 89cc | 2 | 2 | 2 | 2 | 2 |

Chart 2

* Using unmodified heads with .045" head gaskets.

- OK No Clearancing needed.
- 1 Valve to piston clearances must be checked.
- 2 Valve pockets in pistons must be modified.

INSTALLATION

1. Remove Cam Chain Drive

NOTES:

- Changing camshafts and cam drives in Twin Cam 88® engines is different than in previous engines. Procedure requires use of a hydraulic press and some special tools. Installation should be done by an experienced mechanic with access to a factory service manual and all required tools.
- Tighten all fasteners to correct specifications and in order described. Always use an accurate torque wrench.

⚠ CAUTION

Incorrect installation can cause engine damage not covered under warranty.

⚠ WARNING

Failure to install components correctly can result in sudden engine seizure. Engine seizure may result in serious injury to motorcycle operator, passenger, or others.

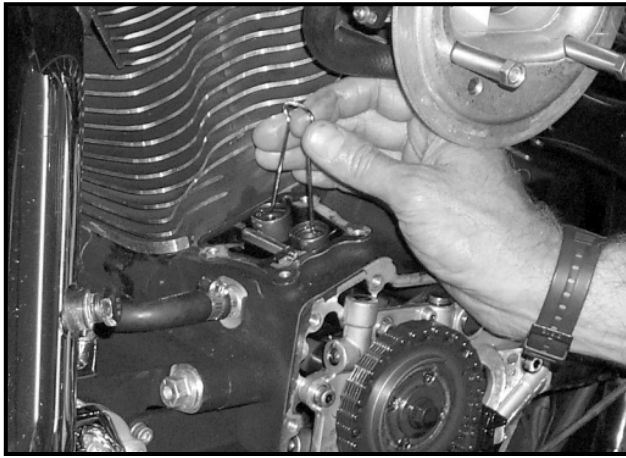

Picture 1

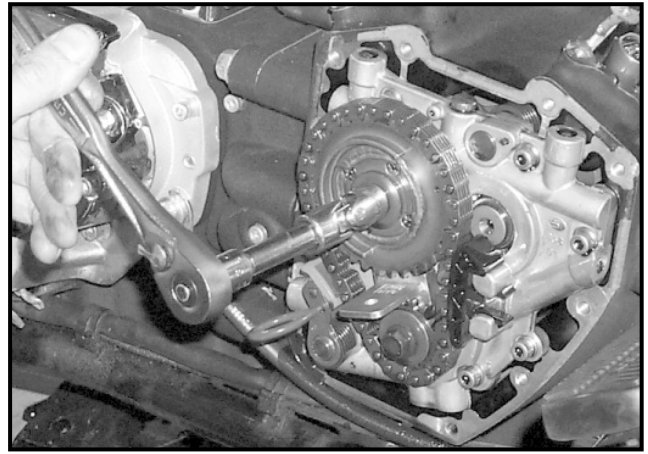

Picture 2

- A. Disconnect battery ground cable to eliminate potential sparks and inadvertent engagement of starter while working on motorcycle.
- B. Remove spark plugs and pushrod cover clips. Collapse pushrod covers to expose pushrods.
- C. Safely elevate and stabilize rear of motorcycle. Place transmission in high gear. Turn rear wheel to rotate engine until both lifters and pushrods for either cylinder are at lowest point on camshaft (TDC of compression stroke). Both intake and exhaust pushrods for that cylinder will not be under pressure from the valve springs and will rotate with light finger pressure.

NOTE: 510G camshafts may use stock style non-adjustable pushrods instead of adjustable pushrods. If installing non-adjustable pushrods, disassemble and assemble rocker box per Harley-Davidson® instructions. All other S&S® gear drive cams require installing adjustable pushrods. As a time-saving measure, the stock pushrods can be removed with bolt cutters. Be sure to heed cautions and warnings in these instructions.

- D. Cut pushrods for cylinder that is at TDC with bolt cutter and remove pushrods and pushrod covers from engine. Rotate engine to place pushrods for other cylinder at their lowest point. Cut and remove remaining pushrods.

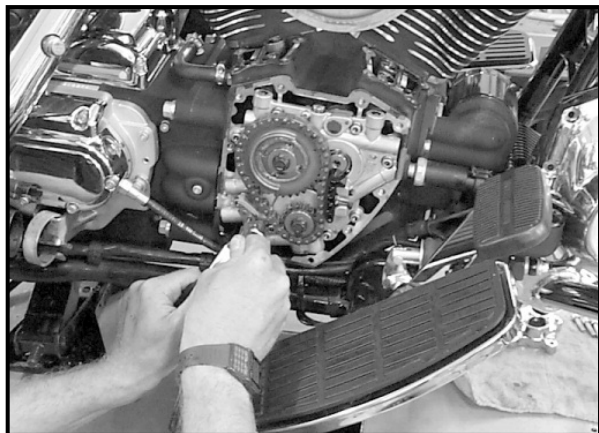

Picture 3

⚠ CAUTION

Cutting pushrods with a saw or cutoff wheel may result in debris entering engine, causing extensive engine damage not covered under warranty.

⚠ WARNING

Cutting pushrods without releasing spring pressure, by rotating engine until tappets are at lowest point of travel, can result in bodily injury.

- E. Remove pushrod and lifter covers from crankcase.
- F. Remove engine cam cover and gasket. It is not necessary to remove ignition sensor from cover. Secure lifters with a tool made from a large binder clip. See Picture 1.
- G. Remove bolts and washers from cam drive sprocket and crankshaft sprocket.

NOTE: S&S recommends using Harley-Davidson® sprocket locking tool H-D® #42314 to secure sprockets while bolts are being removed. See Picture 2.

- H. Use Harley-Davidson® cam chain tensioner unloader H-D® #42313 to move tensioner away from primary cam chain. Secure tensioner with retention pin. See Picture 3.



Picture 4

All references to Harley-Davidson® part numbers is for identification purposes only. We in no way are implying that any of S&S® Cycle's products are original equipment parts or that they are equivalent to the corresponding Harley-Davidson® part number shown.

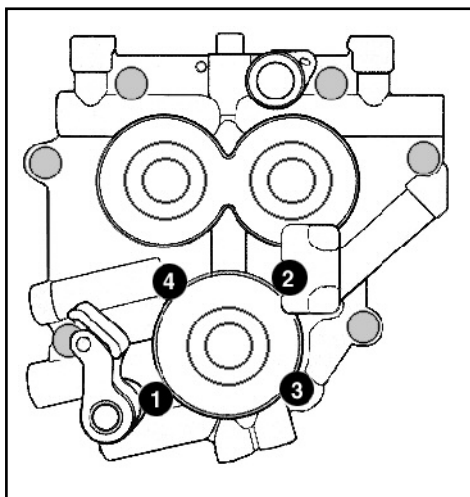

Figure 1

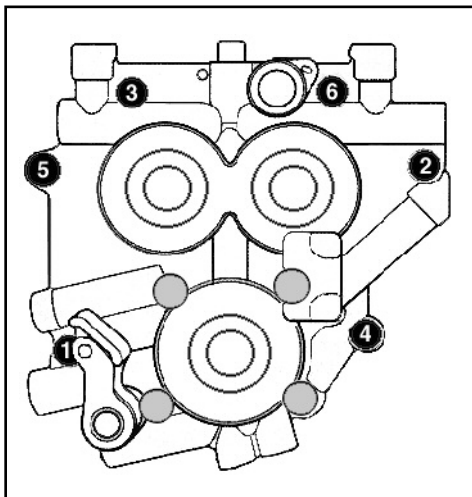

Figure 2

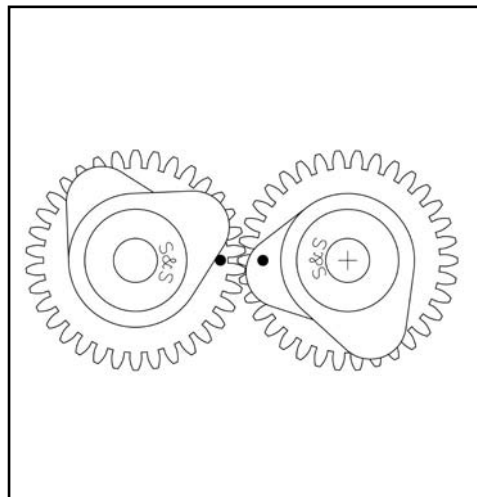

Figure 3

- I. Working gradually around edge of each sprocket, carefully pry sprockets loose. Remove sprocket and chain assembly.
- J. Remove chain guide. See Picture 4.
- K. Following sequence shown, alternately loosen and remove oil pump bolts. See Figure 1.
- L. Following sequence shown, alternately loosen and remove cam support plate bolts. See Figure 2.

CAUTION

Failure to remove and install bolts according to correct procedure may result in parts damage not covered under warranty.

- M. Carefully remove cam support plate assembly from case.

All references to Harley-Davidson® part numbers is for identification purposes only. We in no way are implying that any of S&S® Cycle's products are original equipment parts or that they are equivalent to the corresponding Harley-Davidson® part number shown

NOTE: It is not necessary to remove oil pump from engine to complete this installation unless grinding in gear case must be performed for clearancing. If grinding is to be done all gear case components must be removed and all holes taped off with duct tape to avoid contamination of engine with chips.

- N. Use Harley-Davidson® cam chain tensioner unloader H-D® #42313 to move tensioner away from secondary cam chain. Secure tensioner by inserting second retention pin through front of support plate.
- O. Remove bearing retainer screws and bearing retainer from cam support plate.
- P. With cam support plate positioned securely in a hydraulic press, use Harley-Davidson® camshaft remover/installer H-D® #43644 to press both camshafts and bearings from support plate simultaneously.

NOTES:

- Cam bearings may have a loose fit in cam support plate. Camshaft and bearing assemblies may drop out when beginning pressing procedure. Camshafts with roller style bearings will be loose and drop out of support plate.

- The S&S® Gear Drive Cams require that ball bearings be used for both front and rear camshaft outer bearings. The roller bearing used for the rear camshaft in some stock engines has too much internal clearance. This allows center to center distance of gears to vary, causing excessive gear noise. Since the gear drive does not exert a large side load on the rear camshaft, the higher load handling capacity of the roller style bearing is not required.

- Q. Use Harley-Davidson® cam chain tensioner unloader H-D® #42313 to remove retention pin from either tensioner. Allow tensioner to completely relax. Remove retaining ring and tensioner assembly from cam support plate. Repeat this procedure for remaining tensioner.

2. Install Gear Drive Cams

NOTE: Do not reuse cam bearings. If S&S Camshaft Installation Kit 33-5163 is not being used, new bearings should be obtained from another source and installed with new camshafts. The S&S Gear Drive Cams require that ball bearings be used for both front and rear camshaft outer bearings.

- A. Apply assembly lube to outer races of cam bearings and bearing bores in support plate. With cam support plate positioned securely in a hydraulic press, use Harley-Davidson® camshaft remover/installer H-D® #43644 to install both bearings. See Picture 5.



Picture 5

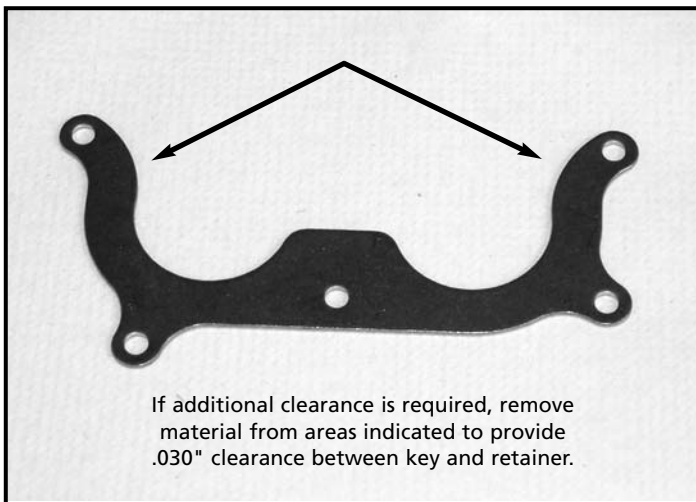

Picture 6

NOTE: Check clearance between bearing retainer and woodruff keys securing inner gears to cams. Remove material from retainer, to provide .030" clearance between key and retainer. See Picture 6.

- B. Align hole in bearing retainer with oil passage in support plate. Install bearing retainer screws with a drop of blue Loctite® threadlock 242 or 243 and tighten screws to 20-30 in-lbs. torque.
- C. Apply assembly lube to outer bearing surface of front (shorter) camshaft and inner race of front bearing. Support bearing by inner race and press camshaft all the way into bearing. Install retaining ring on outer end of front camshaft.

NOTE: Do not reuse retaining ring. If S&S® Camshaft Installation Kit 33-5163 is not being used, a new retaining ring be obtained from another source and installed with new camshaft.

- D. Apply assembly lube to outer bearing surface of rear (longer) camshaft and inner race of rear bearing. Support bearing by inner race and with camshaft gear timing marks aligned (See Figure 3), press camshaft all the way into bearing.

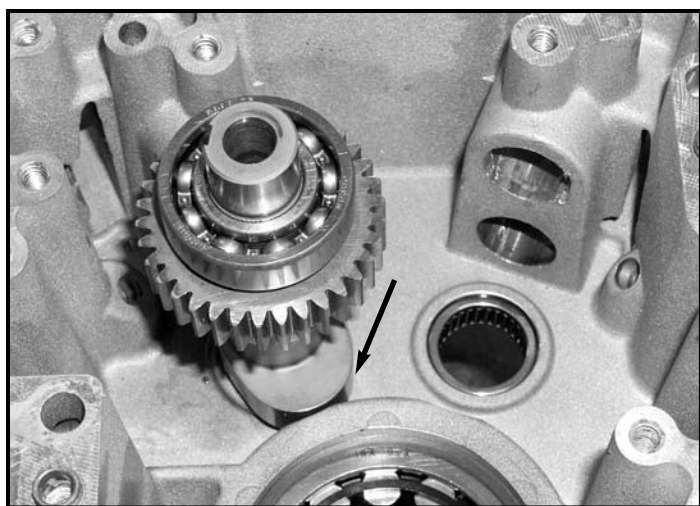

Picture 7

- E. When using 585G, 625G, or 640G camshafts (33-5168, 33-5170, or 33-5172) clearance between pinion bearing boss and rear cam lobe must be checked. See Pictures 7 & 8. Remove just enough material to provide .030" clearance between top of cam lobe and pinion bearing boss when camshaft is rotated in inner needle bearing. Also check clearance between all cam lobes and tappet guide bosses. To avoid contamination of engine with chips, we recommend that all holes in the gear case be taped off with duct tape and that gear case be thoroughly cleaned with parts cleaner or solvent after clearancing is performed.
- F. Carefully remove camshaft needle bearings from crankcase with Harley-Davidson® camshaft needle bearing remover/installer H-D® #42325, and replace them with new bearings provided in S&S Camshaft Installation Kit 33-5163, or with bearings from another source. Cam bearings must be Torrington B148 full complement bearing or equivalent.

NOTE: Before reinstalling cam support plate, make sure oil pump O-rings are in good condition and remain in place during following procedure. Replace worn or damaged O-rings if necessary.

- G. Apply a thin layer of assembly lube to cam journals, lobe surfaces, and inner bearing surfaces. Align camshafts with needle bearings and carefully slide support plate over crankcase dowels.

NOTE: Support plate assembly should slide into place without resistance. If resistance is encountered, determine cause and correct problem before proceeding. Do not force support plate into position!

- H. Loosely install support plate screws with a drop of Loctite® threadlock 242 or 243 (blue). Alternately tighten screws to 95 in-lbs. torque following sequence shown. See Figure 2.

⚠ CAUTION

Support plate screws that pass through alignment dowels (See positions 1 & 2 in Figure 2) can be easily stripped when applying maximum 120 in-lbs. torque as recommended by Harley-Davidson®.

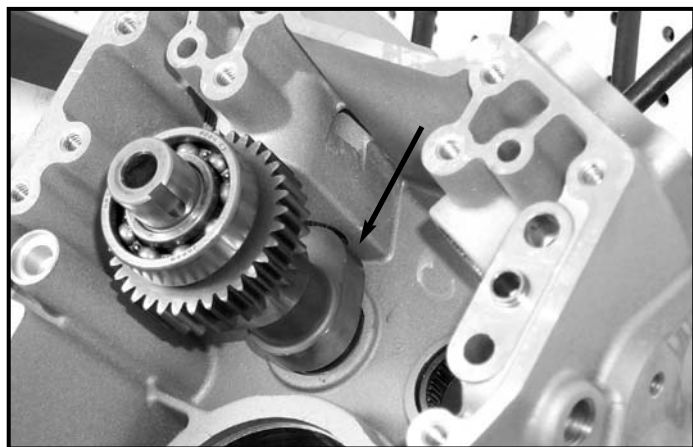

Picture 8

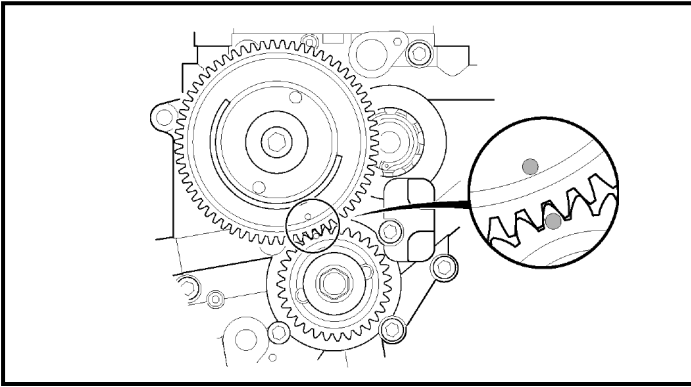

Figure 4

- I. Install oil pump mounting bolts with a drop of Loctite® threadlock 242 or 243 (blue) according to procedure found in factory service manual: Gently bottom screws, then back them out ¼ turn. Center oil pump by rotating engine by hand while snugging down screws. Alternately tighten bolts to 95 in-lbs. torque in sequence shown. See Figure 1. Before moving forward, verify that inner drive gears rotate freely and no binding is present.

NOTE: Crankshaft and cam drive gears have a light press fit on their respective shafts. Start gears squarely on their shafts and use their mounting bolts to pull them all the way into position.

NOTE: Make sure that no metal burrs are raised when installing the gear sets. Burrs can form underneath the gear causing excessive gear run out.

Checking the inner cam gear and outer drive gear sets for backlash:

It is important to check the inner 31 teeth gear set and the outer drive gear set (pinion 31 teeth gear and cam drive 62 teeth gear) for the correct backlash before installing the rest of the valve train components. Backlash, the measure of free play between the gear set, must be checked with no loading applied to the cams and in the four different camshaft positions. To check the backlash of the inner cam gears, lock the front cam into a position by applying a force to the cam lobe. Measure the backlash by moving the rear cam set back and forth. To check backlash in the outer drive gear set, rotate the 62 teeth cam drive gear back and forth while keeping the pinion gear locked in one place with the engine. The minimal required backlash for the gear sets should be between .0005" and .001" and no more than .002" for cold gears. The both gear sets should roll freely with no radial or axial binding. If when checking backlash the gear mesh shows less than .0005" of backlash then a smaller crankshaft gear size 33-4160X for the outer gears or 33-4272RX for the inner gears should be used. Gear sets with less than .005" of backlash may whine when run and can cause tooth wear excessive heat generation and gear failure resulting in engine damage. Gear backlash greater than .002" can cause excessive gear noise or clicking caused by the reversing of the forces applied by the lifter springs onto the gears, use the oversized crankshaft gear 33-4160Z for the outer gears and 33-4272RZ for the inner gears to correct this condition.

- J. Place crankshaft gear on crankshaft with timing mark outward. Apply a drop of red Loctite® threadlock 262, 271 or 272 to threads of ⅝"-18 x ¼" Grade 8 crankshaft gear bolt, provided in S&S® Camshaft Kit 33-5163 or obtained from another source. Apply a drop of clean

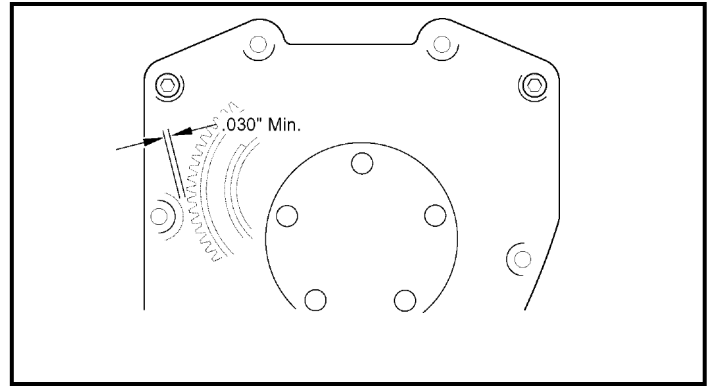

Figure 5

20W-50 engine oil under bolt flange. Using the washer removed in disassembly step G, install crankshaft gear bolt and tighten to 25 ft-lbs. torque.

- K. If necessary, place transmission in high gear and turn rear wheel to rotate engine until timing mark on crankshaft gear is in position. See Figure 4.
- L. Place drive gear key in rear camshaft. Position cam drive gear on rear camshaft and key with timing mark outward. Rotate drive gear and camshafts until drive gear and crankshaft gear timing marks are aligned. See Figure 4.
- M. Apply a drop of red Loctite® threadlock 262, 271 or 272 to threads of ⅝"-24 x 1.75 Grade 8 cam drive gear bolt. Apply a drop of clean 20W-50 engine oil under bolt flange. Using thick washer provided, install cam drive gear bolt and tighten to 34 ft-lbs. torque. Verify that out gear drives rotate freely and no binding is present.

NOTE: Drive gear cams are slightly larger than stock drive sprocket and needs to be checked for interference with cam cover before proceeding.

- N. Press a small piece of clay or kneadable putty on cam cover mounting boss shown. See Figure 5. Carefully hold cover and cover gasket in position against crankcase. Install mounting bolts (4) near corners of cover finger tight. Push or tap cam cover towards front of engine.
- O. Carefully remove cam cover. Determine cover-to-gear clearance by measuring impression left in clay by gear at its thinnest point. Clearance should be .030" or more.

If clearance is less than .030", or if cover contacts gear, remove only enough material from cam cover to obtain correct clearance. Repeat steps M and N if necessary.

CAUTION

Be careful not to grind too deeply and break through to the outside of the cam cover. Damage to cam cover caused by removing too much material is not covered under warranty.

- P. Use a new gasket and install cam cover. Tighten cover bolts to 90-120 in-lbs. torque in sequence shown. See Figure 6.
- Q. Remove clips to release lifters. If necessary, place transmission in high gear and turn rear wheel to rotate engine until both lifters for front cylinder are at lowest point on camshaft (TDC of compression stroke for front piston).

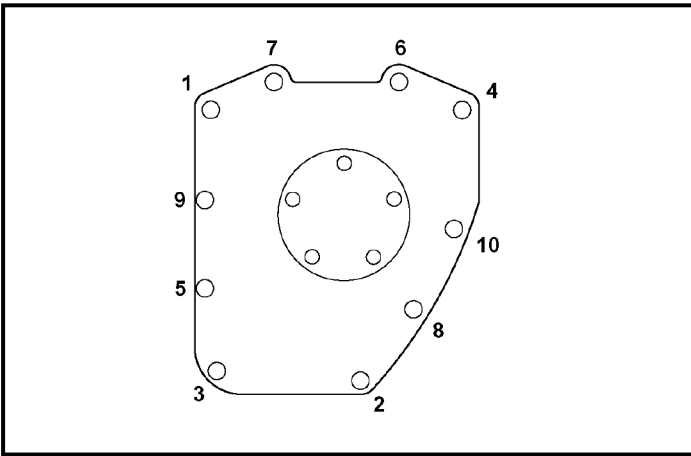

Figure 6

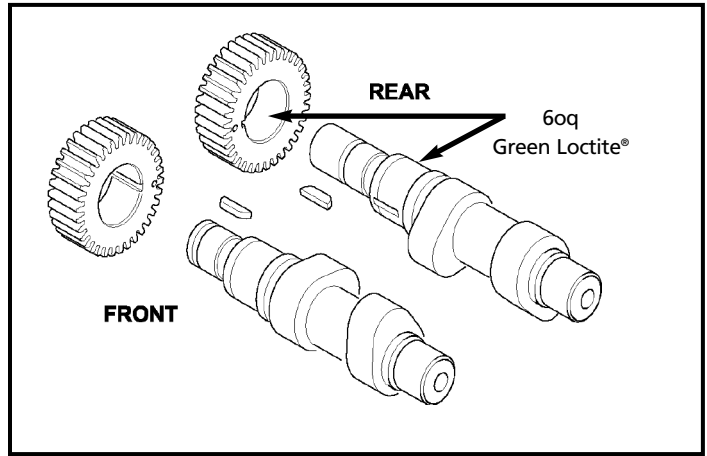

Figure 7

- R. Loosen locknuts on adjustable pushrods and turn adjusters to make all rods as short as possible.
- S. Longer S&S pushrods are for exhaust valves, and shorter ones are for intake. Pass one long and one short pushrod through assembled pushrod covers. Place pushrod and cover assemblies through lifter cover. Inner tappet hole is for intake pushrod, and outer tappet hole is for exhaust pushrod. While holding a new gasket under lifter cover, install push rod, pushrod cover, lifter cover, and gasket as an assembly on crankcase. Tighten lifter cover screws to 95 in-lbs. torque.

NOTE: Pushrod adjustment. If using unmodified original tappets perform steps 3-A thru 3-D to adjust pushrods. (See below.) If S&S HL₂T kit has been installed in tappets, proceed to steps 4-A thru 4-F. (See next page.)

3. Pushrod Adjustment Procedure For Unmodified Stock Tappets

- A. Turn adjuster screw to lengthen exhaust pushrod until pushrod has no vertical movement but still rotates with light finger pressure. Extend pushrod by rotating adjuster screw an additional 20 flats (3½ revolutions) and secure adjuster screw with locknut.
- B. Repeat step 2-5 for intake pushrod.
- C. Front lifters should bleed down in 5-10 minutes, allowing pushrods to be rotated with light finger pressure. Extend pushrod covers and install cover clips.

CAUTION

Rotating engine before lifters have bled down may damage pushrods and other components not covered under warranty.

- E. Rotate engine until both lifters for rear cylinder are at lowest point on camshaft (TDC of compression stroke for rear piston). Repeat steps R-T for rear pushrods.

4. Pushrod Adjustment Procedure - for Tappets With HL₂T Kit Installed

- A. Bring piston to TDC on compression stroke in cylinder to be adjusted. Normally both tappets will be at their lowest point of travel.

- B. Extend pushrod adjustment, collapsing lifter until piston assembly is in contact with HL₂T spacer and pushrod is tight. If tappets contain oil, as when pushrods are readjusted after engine has been run, or if all oil was not removed during HL₂T installation, extend pushrod adjustment until valve is open (about five additional turns of adjusting screw). Allow 5 minutes for hydraulic unit to bleed down. If pushrod can be turned with fingers after bleeding down, lifter is not completely collapsed, and this step must be repeated.

NOTE: Perform this operation on one cylinder at a time. Do not turn engine until pushrod adjustment is complete.

CAUTION

Turning engine while valve is held off the seat could result in valve to valve or valve to piston contact and serious valve train damage.

- C. Loosen pushrod adjustment until pushrod can be rotated with the fingers with slight drag. Pushrod now has zero lash.

NOTES:

- Shortening pushrod adjuster an additional six flats or one full turn from zero lash often results in quieter pushrod operation. This provides additional travel for the hydraulic piston assembly, which can improve the ability of the hydraulic unit to maintain zero lash under normal operating conditions.
- Harley-Davidson® Twin Cam 88® lifters require HL₂T Kit 33-5339 for 1986 and later engines.
- D. Tighten lock nut and recheck pushrod adjustment to insure that it is still correct.
- E. Follow the same procedure for all four push rods.

NOTES:

- After a few hundred miles it is a good idea to recheck pushrod adjustment in a new engine as valve train may tighten up due to gasket compression and valve seat wear.
- Upon initial start up after modification, HL₂T equipped lifters may be somewhat noisy for 10-20 miles. If lifters are still noisy after 20 miles it is recommended that pushrods be adjusted ½ turn looser.

- F. Replace any remaining parts removed to facilitate gear drive cams installation. Check engine oil level. Start engine and check for leaks.

NOTE: Engine may require several miles at normal operating temperature for lifters to fill with oil and quiet valve train.

Service

If crankshaft or cam drive sprocket needs to be removed, S&S® recommends using a small wheel puller like NAPA® #775-9064. Loosen and unscrew gear bolt until bolt flange is about .600" from shaft. To avoid damaging shaft internal threads, let puller screw push against head of gear bolt until gear breaks free from shaft.

For replacement purposes, camshafts and camshaft gears are available separately.

Use a hydraulic press to remove and install camshaft gears. Always use new keys, 60q green Loctite®, and make sure correct gear is mated with correct camshaft. See Figure 7.

Timing marks on camshaft gears should face cam lobes.

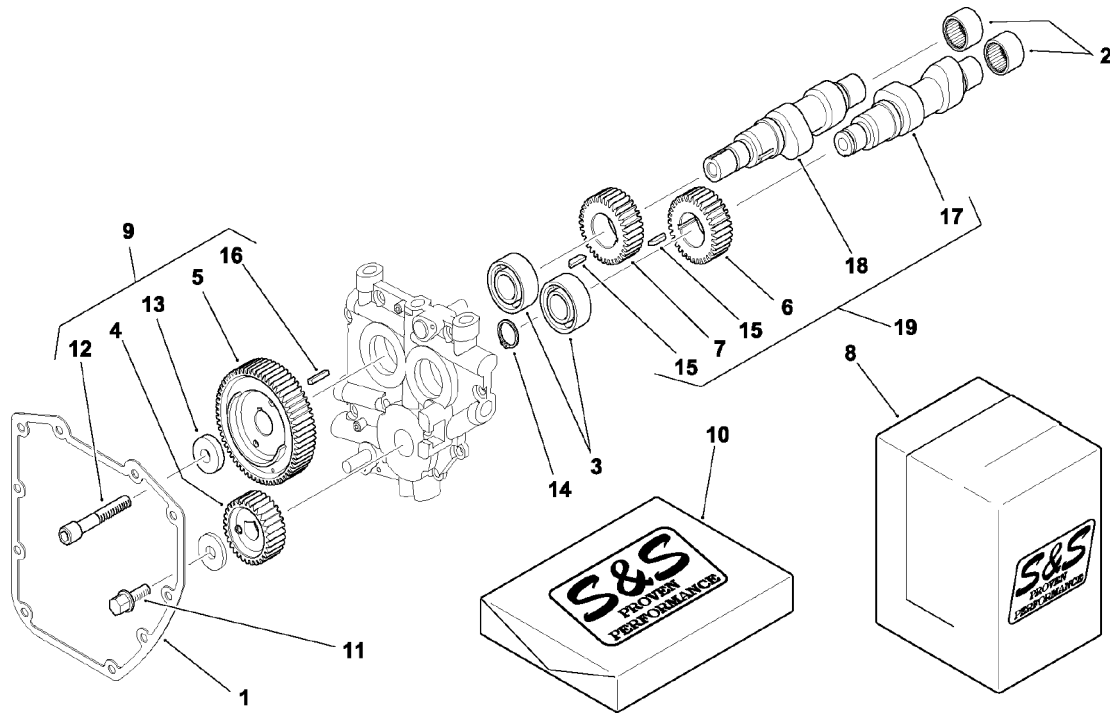

S&S® Gear Drive Cams Assembly Parts

| | | | |
|---|----------|---|----------|
| 1. Gasket, Cam Cover | 31-2032 | 14. Ring, Retaining | 50-8061 |
| 2. Bearing, Needle, Inner Cam (2)..... | 31-4080 | 15. Key, Woodruff .125 x .5 (2)..... | 50-8223 |
| 3. Bearing, Outer Cam, Ball..... | 31-4081 | 16. Key, .188 x .150 x .57 | 50-8226 |
| 4. Gear, Pinion | 33-4160 | 17. Camshaft, Front, 510G | 33-5173F |
| 5. Gear, Cam Drive (Includes reference #12, 13 & 16) | 33-4271 | Camshaft, Front, 570G | 33-5165F |
| 6. Gear, Camshaft, Front (Includes reference #15)..... | 33-4272F | Camshaft, Front, 585G | 33-5167F |
| 7. Gear, Camshaft, Rear (Includes reference #15)..... | 33-4272R | Camshaft, Front, 625G | 33-5169F |
| 8. Kit, Gear Drive Cams (Includes reference #4-7, 12, 13, 15 & 16) | 33-4275 | Camshaft, Front, 640G | 33-5171F |
| 9. Kit, Gear Drive Cams Outer Gears (Includes reference #4, 5, 12, 13 & 16)..... | 33-4276 | 18. Camshaft, Rear, 510G | 33-5173R |
| 10. Kit, Chain Drive Camshaft Installation (Includes reference #1-3, 11 & 14)..... | 33-5163 | Camshaft, Rear, 570G | 33-5165R |
| 11. Screw, HHC 5/16" -18 x 3/4" | 50-0100 | Camshaft, Rear, 585G | 33-5167R |
| 12. Screw, SHC 3/8" -24 x 1 1/4" | 50-0132 | Camshaft, Rear, 625G | 33-5169R |
| 13. Washer, Flat 3/8"x 1 1/8"x .225" | 50-7056 | Camshaft, Rear, 640G | 33-5171R |
| | | 19. Kit, Camshaft, 510G (Includes reference #6, 7, 15, 17 & 18)..... | 33-5174 |
| | | Kit, Camshaft, 570G (Includes reference #6, 7, 15, 17 & 18)..... | 33-5166 |
| | | Kit, Camshaft, 585G (Includes reference #6, 7, 15, 17 & 18)..... | 33-5168 |
| | | Kit, Camshaft, 625G (Includes reference #6, 7, 15, 17 & 18)..... | 33-5170 |
| | | Kit, Camshaft, 640G (Includes reference #6, 7, 15, 17 & 18)..... | 33-5172 |